

# ATLAS® Type AEKC

SpinTite® - Minimized-profile head

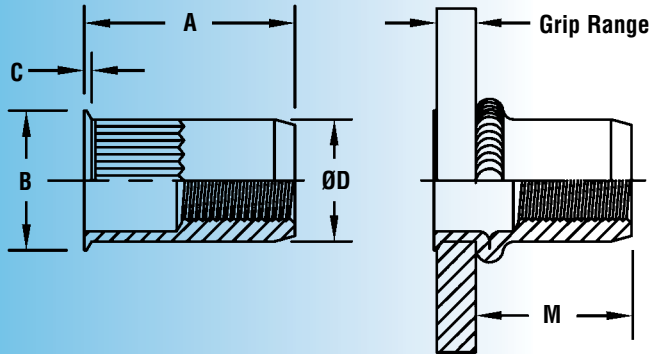

- ### Features and Benefits
- 300 Series Stainless Steel insert for superior corrosion resistance.
  - Feature a large diameter, low-profile head and knurled shank.
  - Offers highest all around strength.
  - Installed with spin/pull tooling.

### PART NUMBER DESIGNATION

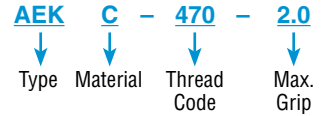

All dimensions are in millimeters.

Thread Size	Part Number	Grip Range	A ±0.38	B ±0.25	C ±0.08	ØD +.000 -0.15	M Ref.	Hole Size In Sheet +0.15
M4 x 0.7	AEKC-470-2.0 (1)	0.5 – 2.0	11.07	7.55	0.50	6.73	7.9	6.75
M4 x 0.7	AEKC-470-3.3 (1)	2.0 – 3.3	12.34	7.55	0.50	6.73	7.9	6.75
M5 x 0.8	AEKC-580-3.0 (1)	0.5 – 3.0	12.56	8.35	0.50	7.52	8.3	7.60
M5 x 0.8	AEKC-580-5.1 (1)	3.0 – 5.1	14.76	8.35	0.50	7.52	8.4	7.60
M6 x 1	AEKC-610-3.3 (1)	0.7 – 3.3	16.17	11.05	0.65	9.91	11.2	10.0
M6 x 1	AEKC-610-5.7 (1)	3.3 – 5.7	18.69	11.05	0.65	9.91	11.3	10.0
M8 x 1.25	AEKC-8125-3.8 (1)	0.7 – 3.8	19.96	15.10	0.85	13.46	13.9	13.5
M8 x 1.25	AEKC-8125-6.6 (1)	3.8 – 6.6	22.90	15.10	0.85	13.46	14.0	13.5
M10 x 1.5	AEKC-1015-3.8 (1)	0.7 – 3.8	19.96	15.10	0.85	13.46	13.9	13.5
M10 x 1.5	AEKC-1015-6.6 (1)	3.8 – 6.6	22.90	15.10	0.85	13.46	14.0	13.5

(1) Not stocked, available on special order.

### Material & Finish Specifications

<b>Fastener Material:</b> 300 Series Stainless Steel	<b>Finish:</b> Passivated
<b>Threads:</b> Metric, 6H per ASME B1.13M	



Specifications subject to change without notice.

**PennEngineering®**



**North America:** Danboro, PA USA • E-mail: atlas@pemnet.com • Tel: +1-215-766-5987 • Fax: +1-215-766-5988 • 877-682-2505 (USA Only)  
**Europe:** Galway, Ireland • E-mail: europe@pemnet.com • Tel: +353-91-751714 • Fax: +353-91-753541  
**Asia/Pacific:** Singapore • E-mail: singapore@pemnet.com • Tel: +65-6-745-0660 • Fax: +65-6-745-2400  
 Shanghai, China • E-mail: china@pemnet.com • Tel: +86-21-5868-3688 • Fax: +86-21-5868-3988

Visit our PEMNET™ Resource Center at [www.pemnet.com](http://www.pemnet.com)