

PEM SERTER[®] SERIES 3000[™]

AUTOMATIC INSERTION PRESS

NEW!

The new **PEMSERTER[®] Series 3000[™] automatic fastener-installation press** can install self-clinching fasteners up to 30% faster than traditional systems to deliver comparable productivity gains. **Full servo electromechanical actuation technology** provides significant improvement in operating consistency, improved reliability, increased efficiencies and minimized maintenance. Total elimination of hydraulic fluids provides an environmentally friendly system.

Featuring
**Full Servo Electromechanical
Actuation Technology**

Features and Benefits

- ▶ **Intelligent Set-up System (ISS).** Automatically determines insertion force requirements.
- ▶ **"Optimized Motion Profiles"**. Eliminates need for "dwell time" and provides optimal fastener insertion.
- ▶ **PC Based Programming.** Push button, menu driven, touch screen control system.
- ▶ **Robot Ready.** Press ships standard with robot interface.
- ▶ **Remote Monitoring.** Monitoring and troubleshooting through ethernet compatibility.
- ▶ **Data Logging.** Internal data for force and distance is measured and stored within the machine. Data collected can be downloaded to Windows operating platforms for QC documentation.
- ▶ **Multiple Pictures of Single Workpiece.** Digital pictures of workpiece for clarification of insertion points.
- ▶ **Multi Language Capable.**
- ▶ **Technical Video.** Pre-loaded on-screen video instructions for machine set-up and tooling changeover.



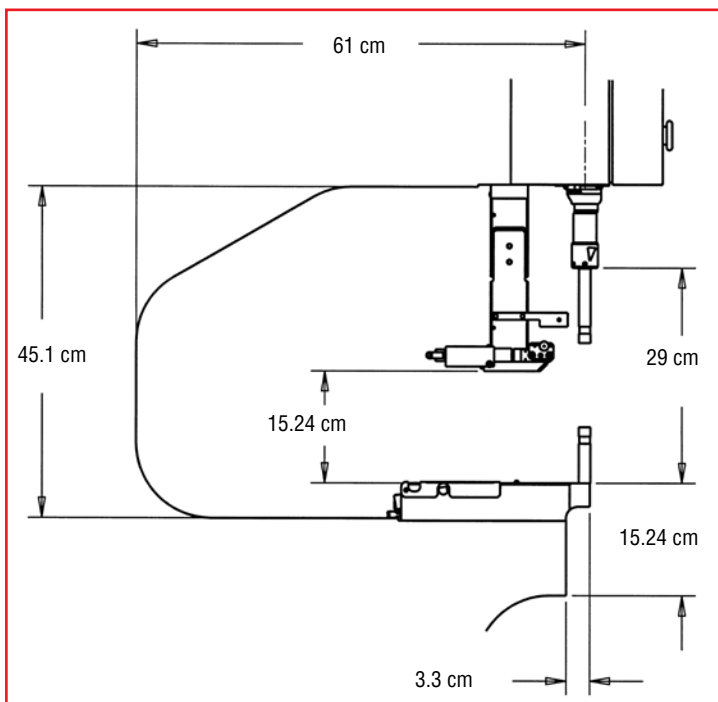

Specifications

Ram Force	1.8 to 71.2 kN
Ram Drive	Servo Electromechanical Actuator
Electric Requirements	240-250VAC, 60Hz, 20A, single phase or 240-250VAC, 50Hz, 20A, single phase
Air Requirements*	5 to 6 BAR 6 mm dia. minimum line flow
Throat Depth	61 cm
Height	208 cm
Width	92 cm
Depth	126 cm
Weight	1,235 kg

The Series 3000 press introduces “clean” technology without hydraulics to install all types of self-clinching fasteners rapidly, accurately, and permanently. The electromechanical servo drive optimizes ram function to achieve ideal and repeatable speed and force for proper fastener installation.

Among features, PC-based programming interfaces with Windows operating platforms for job versatility and customization. Menu-driven touch-screen controls, descriptive screen alerts, and an on-screen multi-media instructional video

contribute to user-friendly operation and quick learning. Data logging capabilities allow for performance monitoring. A patented LIGHTSTREAM® Operator Safety System provides a continuous safeguard by ensuring ram force is applied only to fasteners.



*Specifications subject to change without notice.
Check our website for the most current version of this bulletin.*

© 2008, PennEngineering

PennEngineering®



North America: Danboro, PA USA • E-mail: info@pemnet.com • Tel: +1-215-766-8853 • Fax: +1-215-766-0143 • 800-237-4736 (USA Only)
Europe: Galway, Ireland • E-mail: europe@pemnet.com • Tel: +353-91-751714 • Fax: +353-91-753541
Asia/Pacific: Singapore • E-mail: singapore@pemnet.com • Tel: +65-6-745-0660 • Fax: +65-6-745-2400
 Shanghai, China • E-mail: china@pemnet.com • Tel: +86-21-5868-3688 • Fax: +86-21-5868-3988

Visit our PEMNET™ Resource Center at www.pemnet.com