

PennEngineering®

KEYHOLE® STANDOFFS AND FASTENERS



BULLETIN

SK



609  
REV. 909

# KEYHOLE® SELF-CLINCHING STANDOFFS AND SHEET JOINING FASTENERS

PEM® KEYHOLE® Standoffs (Type SKC™) and sheet joining fasteners (Type SKC-F™) are designed so that a PC board or panel can be quickly slipped into place and then removed from an assembly by simply sliding the board sideways and lifting it off. PEM KEYHOLE fasteners can save valuable time and dramatically reduce the amount of loose hardware required. Type SKC can be used for spacing or hanging of replaceable components. Typically, several SKC standoffs are used with one standard PEM threaded standoff which accepts a screw to secure the board or component against any unwanted movement. Type SKC-F is designed so that two sheets can be quickly joined flat against each other. Typically, several Type SKC-F fasteners are used with one standard PEM® threaded Type F flush nut which accepts a screw to secure the sheets against any unwanted movement.

## **Type SKC - Allows detachable spacing of two sheets**

- Clinch feature mounts fastener permanently into metal sheet.
- Unique barrel design allows for quick attachment and detachment.
- Head is flush with one side of metal sheet.
- Makes horizontal or vertical component mounting possible.

## **Type SKC-F - Allows detachable joining of two sheets**

- Clinch feature mounts fastener permanently into metal sheet.
- Unique barrel design allows for quick “panel-on-panel” attachment and detachment.
- Head is flush or sub-flush with one side of metal sheet.
- Can be clinched into blind hole where concealed-head is required.
- Makes horizontal or vertical component mounting possible.

## **TYPE SKC STANDOFFS**



## **TYPE SKC-F FASTENERS**



# DIMENSIONAL DATA

## TYPE SKC DIMENSIONAL DATA

Look for the PEM "dimple" trademark.

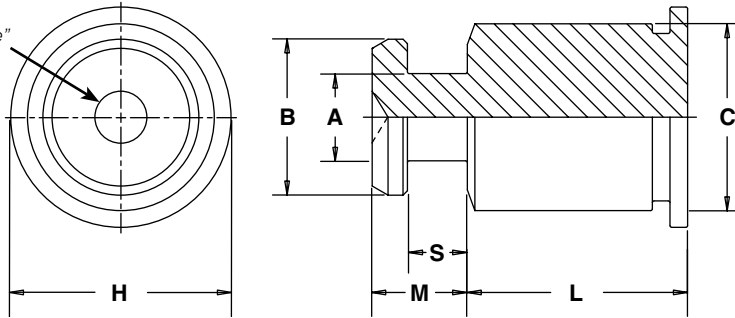

### PART NUMBER DESIGNATION

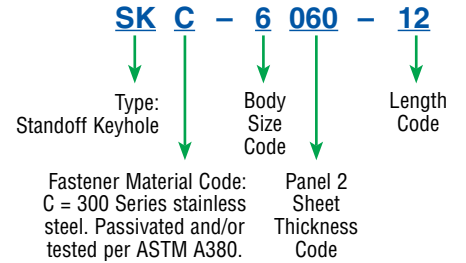

All dimensions are in millimeters.

METRIC	Type	Body Size - Sheet Code	Length "L" ± 0.13 (Length Code in millimeters)												A	B	C	S	M	H	D
	Stainless Steel														± 0.08	± 0.08	Max.	± 0.08	Max.	Nom.	Anvil Hole + 0.08
	SKC	61.5	2	4	6	8	10	12	14	16	18	20	22	25	2.51	4.5	5.39	1.72	2.75	6.35	5.49

## TYPE SKC-F DIMENSIONAL DATA

Look for the PEM "dimple" trademark.

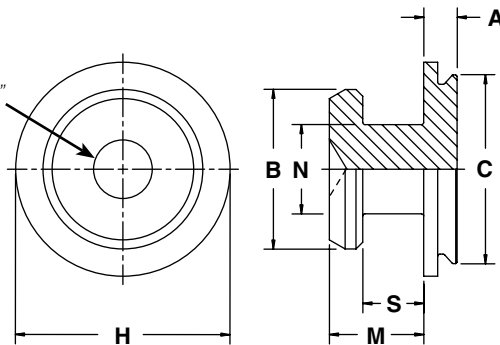

### PART NUMBER DESIGNATION

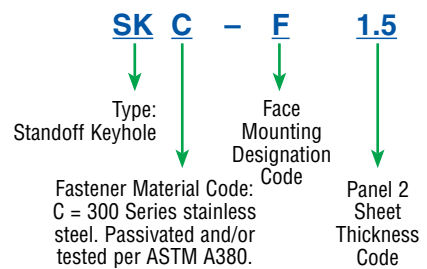

All dimensions are in millimeters.

METRIC	Type	Face Mounting Designation Code	Sheet Thickness Code	A	B	C	H	M	N	S	D
	Stainless Steel			Max.	± 0.08	Max.	Nom.	Max.	± 0.08	± 0.08	Anvil Hole + 0.08
	SKC	F	1.5	1	4.5	5.39	6.02	2.75	2.5	1.72	4.67

# APPLICATION DATA

## TYPE SKC

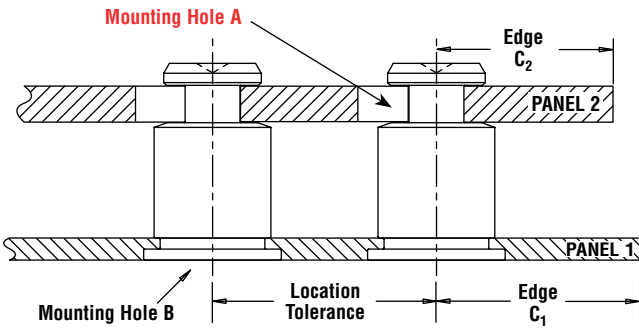

## TYPE SKC-F

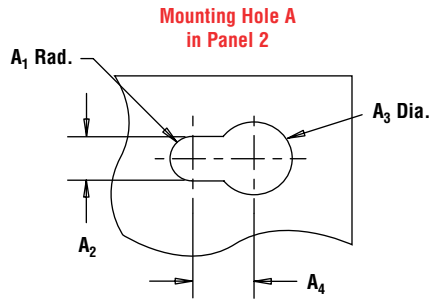
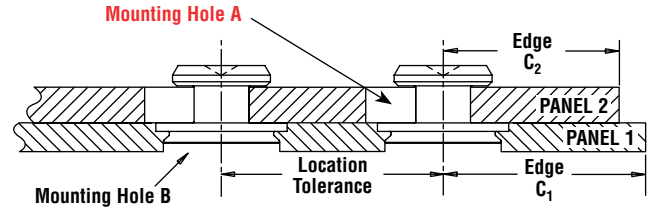

All dimensions are in millimeters.

METRIC	Type	PANEL 1					PANEL 2						
		Bottom Mounting Hole B +0.08	Sheet Hardness Max. (1)	Min. Sheet Thickness	Edge Distance C <sub>1</sub> Min.	Location Tolerance Max.	Top Mounting Hole A				Material	Thickness Range	Edge Distance C <sub>2</sub> Min.
							A <sub>1</sub> Nom.	A <sub>2</sub> ± 0.08	A <sub>3</sub> ± 0.08	A <sub>4</sub> Min.			
SKC	5.41	HRB 70 / HB 125	1.02	6.6	± 0.13	1.5	3	5	3.75	ANY	1.45 - 1.62	4.1	
SKC-F	5.41	HRB 70 / HB 125	1 (2)	3.8	± 0.13	1.5	3	5	3.75	ANY	1.45 - 1.62	4.1	

(1) HRB - Hardness Rockwell "B" Scale. HB - Hardness Brinell.

(2) Type SKC-F may also be installed into a 1.1mm deep blind milled hole in a 1.6mm minimum sheet thickness.

# INSTALLATION

## TYPE SKC

1. Prepare properly sized mounting hole in Panel 1.
2. Place the barrel of the fastener through mounting hole and into anvil as shown in drawing to the right.
3. With the punch and anvil surfaces parallel, apply only enough squeezing force to embed the head flush with the panel.

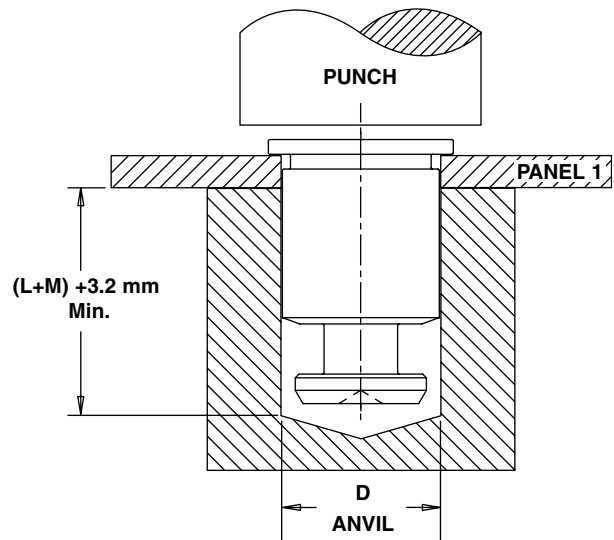

## TYPE SKC-F

### Through Hole Installation Procedure

1. Prepare properly sized mounting hole in Panel 1.
2. Place the fastener into anvil hole as shown in the drawing to the right.
3. Place the panel over the shank of the fastener.
4. With the punch and anvil surfaces parallel, apply only enough squeezing force until flange is flush with panel.

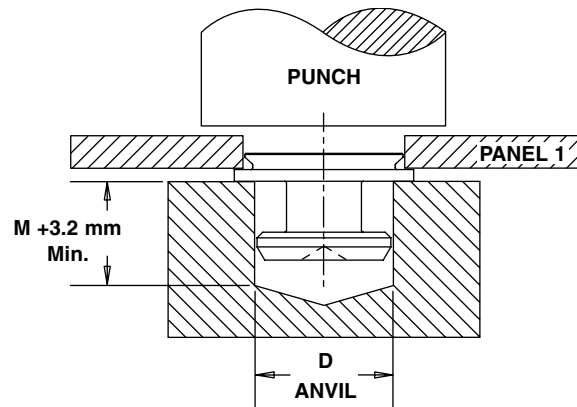

### Blind Hole Installation Procedure

1. Mill a properly sized blind hole to 1.1mm minimum depth.
2. Place the fastener into anvil hole as shown in the drawing to the right.
3. Place the panel over the shank of the fastener.
4. With the punch and anvil surfaces parallel, apply only enough squeezing force to embed the flange flush with the panel.

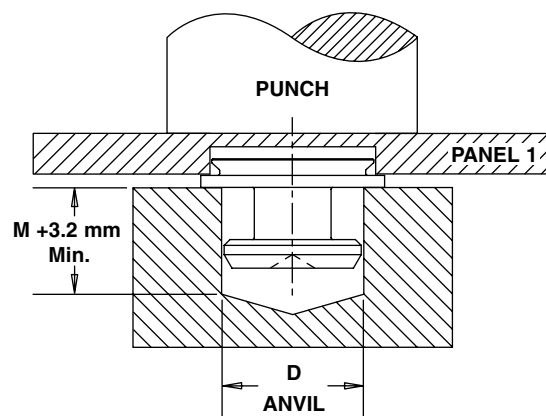

# PERFORMANCE DATA<sup>(1)</sup>

## TYPE SKC

### Installation and Pushout

Test Sheet Material →		1.52 mm 5052-H34 Aluminum			1.52 mm Cold-Rolled Steel		
METRIC	Body Size - Sheet Code	Installation (kN)	Pushout (N)	Installation (kN)	Pushout (N)	Installation (kN)	Pushout (N)
		61.5	7.1	1100	14.2	2600	

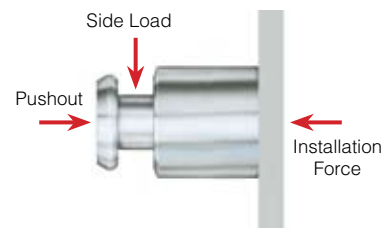

### Side-Load

Test Sheet Material →		5052-H34 Aluminum											Cold-Rolled Steel													
Test Sheet Thick. →		1 mm <sup>(2)</sup>		1.5 mm									1 mm <sup>(2)</sup>		1.5 mm											
METRIC	Body Size - Sheet Code	Length Codes																								
			-2	-4	-6	-8	-10	-12	-14	-16	-18	-20	-22	-25	-2	-4	-6	-8	-10	-12	-14	-16	-18	-20	-22	-25
			Side-Load Force Max. (N)											Side-Load Force Max. (N)												
	61.5	545	370	296	228	184	156	136	116	104	96	88	76	735	490	696	540	440	372	320	280	252	228	208	184	

## TYPE SKC-F

### Installation, Pushout and Side-Load

Test Sheet Material →		1.52 mm 5052-H34 Aluminum			1.52 mm Cold-Rolled Steel		
METRIC	Type	Installation (kN)	Pushout (N)	Side-Load Force Max. (N)	Installation (kN)	Pushout (N)	Side-Load Force Max. (N)
		SKC-F	4.9	533	533	9.3	711

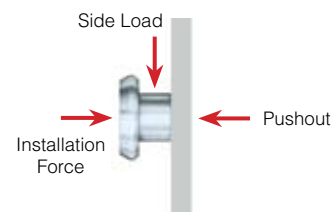

- (1) The values reported are averages when all installation specifications and procedures are followed. Variations in mounting hole size, panel material and installation procedure will affect this data. Performance testing of this product in your application is recommended. We will be happy to provide samples for this purpose.
- (2) 1mm test sheet material thickness was used for the -2 and -4 SKC standoffs due to the short length of the parts.

RoHS compliance information can be found on our website.

Specifications subject to change without notice.  
Check our website for the most current version of this bulletin.

**PennEngineering®**



**North America:** Danboro, PA USA • E-mail: info@pemnet.com • Tel: +1-215-766-8853 • Fax: +1-215-766-0143 • 800-237-4736 (USA Only)  
**Europe:** Galway, Ireland • E-mail: europe@pemnet.com • Tel: +353-91-751714 • Fax: +353-91-753541  
**Asia/Pacific:** Singapore • E-mail: singapore@pemnet.com • Tel: +65-6-745-0660 • Fax: +65-6-745-2400  
 Shanghai, China • E-mail: china@pemnet.com • Tel: +86-21-5868-3688 • Fax: +86-21-5868-3988

Visit our PEMNET™ Resource Center at [www.pemnet.com](http://www.pemnet.com)