

PEM® Type TP4™ Self-clinching Pilot Pins

TP4-309
Rev. 409

for installation into stainless steel



TP4 flush-head pilot pins are installed by placing them in properly sized holes in the sheet and squeezing into place with any standard press. TP4 pins are specifically designed for installation into stainless steel sheets as thin as 1 mm. The squeezing action embeds the head of the pin into the sheet. The metal displaced by the head flows smoothly and evenly into the annular groove – creating a flush-head assembly and securely locking the pin into the sheet.



Features and Benefits

- Flush mounts into stainless steel panels.
- Satisfies a wide range of positioning, pivot, and alignment applications.
- Chamfered end makes mating hole location easy.
- RoHS compliant.

The new Type TP4 pins join a full line of self-clinching fasteners for stainless steel applications. For more types consult PEM Bulletin SS on the literature section of our website at www.pemnet.com.

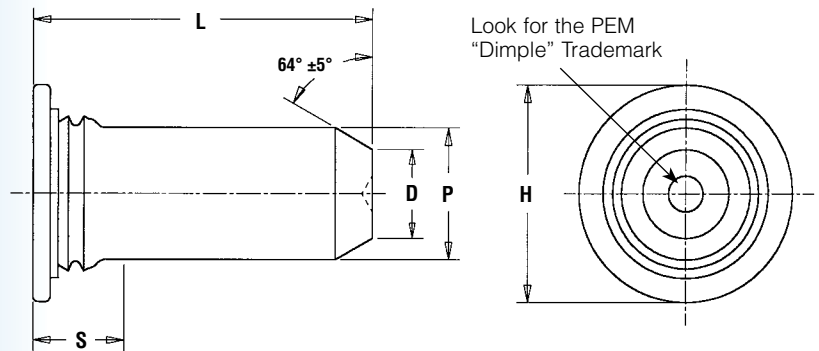

All dimensions are in millimeters.

METRIC	Pin Diameter P ±0.05	Type Stainless Steel	Pin Diameter Code	Length Code "L" ± 0.4 (Length Code in millimeters)				Min. Sheet Thickness	Hole Size in Sheet +0.08	D ±0.15	H ±0.4	S Max. (1)	Min. Distance Hole C/L to Edge
	3	TP4	3mm	8	10	12	16	NA	1	3.5	2.05	5.2	2.29
4	TP4	4mm	8	10	12	16	NA	1	4.5	2.82	6.12	2.29	7.1
5	TP4	5mm	NA	10	12	16	20	1	5.5	3.53	7.19	2.29	7.6
6	TP4	6mm			12	16	20	1	6.5	4.24	8.13	2.29	7.9

(1) Pin diameter may exceed max. in this region.
NA Not Available.

Material & Finish Specifications

Fastener Material: Hardened 400 Series Stainless Steel

Finish: Passivated and/or tested per ASTM A380

For Use In Sheet Hardness: HRB 92 / HB 195 or less ⁽²⁾

(2) HRB - Hardness Rockwell "B" Scale. HB - Hardness Brinell.

PART NUMBER DESIGNATION

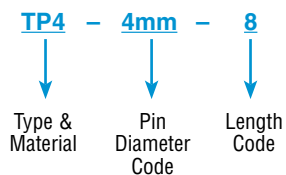

PEM® Type TP4™ Self-clinching Pilot Pins

Performance Data⁽¹⁾

METRIC	Pin Diameter Code	Installation (kN)	Pushout (N)
	3mm	35	1556
	4mm	45	2335
	5mm	54	2535
	6mm	60	2891

(1) The values reported are averages when all installation specifications and procedures are followed. Variations in mounting hole size, sheet material, and installation procedure will affect this data. Performance testing of this product in your application is recommended. We will be happy to provide samples for this purpose or perform the installation for you.

Installation

- 1) Prepare properly sized mounting hole in sheet. Do not perform any secondary operations such as deburring.
- 2) Insert pin through mounting hole of sheet and into anvil hole.
- 3) With punch and anvil surfaces parallel, apply squeezing force to embed the pin's head flush in the sheet.

All dimensions are in millimeters.

METRIC	Type	Pin Dia. Code	Test Sheet Thickness	Anvil Dimensions	
				A ±0.05	C ±0.05
	TP4	3mm	1 - 1.7	3.88	3.13
			Over 1.7	(1)	
	TP4	4mm	1 - 1.7	4.88	4.13
			Over 1.7	(1)	
	TP4	5mm	1 - 1.8	5.89	5.13
			Over 1.8	(1)	
	TP4	6mm	1 - 1.9	6.89	6.13
			Over 1.9	(1)	

(1) Chamfered anvil not required.

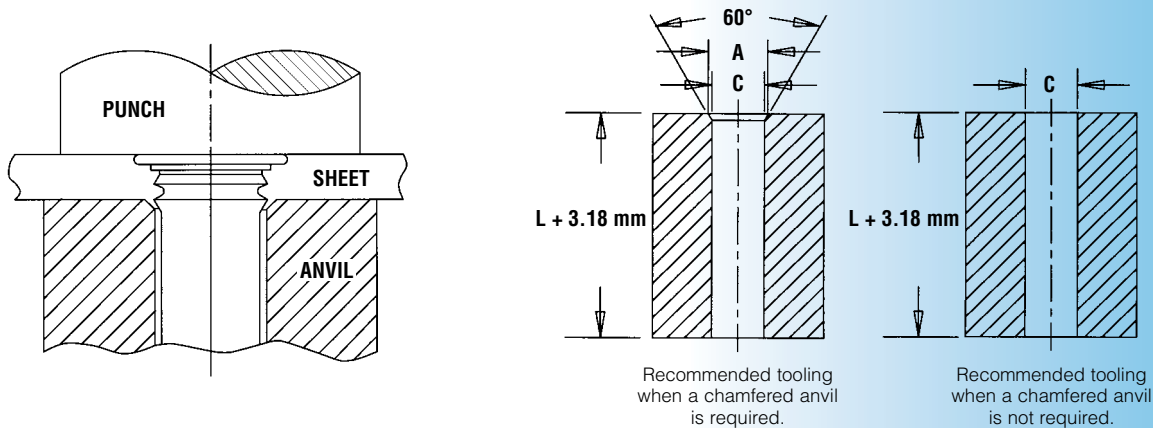

To be sure that you are getting genuine PEM® brand self-clinching pins, look for the "dimple" trademark. (Reg. Pat. & T.M. Off. of the U.S. and other countries.)

The Trademark for Quality

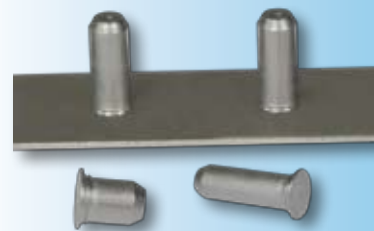

RoHS compliance information can be found on our website.
© 2009 PennEngineering.

Specifications subject to change without notice.
Check our website for the most current version of this bulletin.

PennEngineering®



North America: Danboro, PA 18916 USA • E-mail: info@pemnet.com • Tel: +1-215-766-8853 • Fax: +1-215-766-0143 • 800-237-4736 (USA Only)
U.K. And Europe: Doncaster, England • E-mail: uk@pemnet.com Tel: +44 (0)1302 765700 • Fax: +44 (0)1302 367580
Asia/Pacific: Singapore • E-mail: singapore@pemnet.com • Tel: +65-6-745-0660 • Fax: +65-6-745-2400
Shanghai, China • E-mail: china@pemnet.com • Tel: +86-21-5868-3688 • Fax: +86-21-5868-3988

TP4-2

Visit our PEMNET™ Resource Center at www.pemnet.com