



AE 938
HYDRO-PNEUMATIC TOOL
WITH OIL PRESSURE REGULATION
OPERATING INSTRUCTIONS



PennEngineering®



North America: Danboro, PA USA • E-mail: atlas@pemnet.com • Tel: +1-215-766-5987 • Fax: +1-215-766-5988 • 877-682-2505 (USA Only)
Europe: Galway, Ireland • E-mail: europe@pemnet.com • Tel: +353-91-751714 • Fax: +353-91-753541
Asia/Pacific: Singapore • E-mail: singapore@pemnet.com • Tel: +65-6-745-0660 • Fax: +65-6-745-2400
Shanghai, China • E-mail: china@pemnet.com • Tel: +86-21-5868-3688 • Fax: +86-21-5868-3988

Visit our PEMNET™ Resource Center at www.pemnet.com

**NOTE: THE AE 938 TOOL COMES WITHOUT NOSE ASSEMBLY KITS.
NOSE ASSEMBLY KITS HAVE TO BE ORDERED SEPARATELY ACCORDING TO THE USER NEEDS.**

1. Air piston return (without spring).
2. Power piston air outwardly, not through the piston.
3. Kit assembly with toothed ring nut (wrench no longer necessary).
4. Tie rods are now replaced by commercial screws.
5. Additional unscrewing in case the user installs the wrong insert, or in case it gets stuck due to an improper regulation.
6. One position trigger mechanism.
7. No adjustments are needed when there is a thickness change in materials.
8. No damages occurs to mandrel (or tie rod) if operations are repeated.
9. Lightweight.
10. Small dimensions.

RIV938 AND RIV938S

PROTECTIVE WING

(optional accessory)

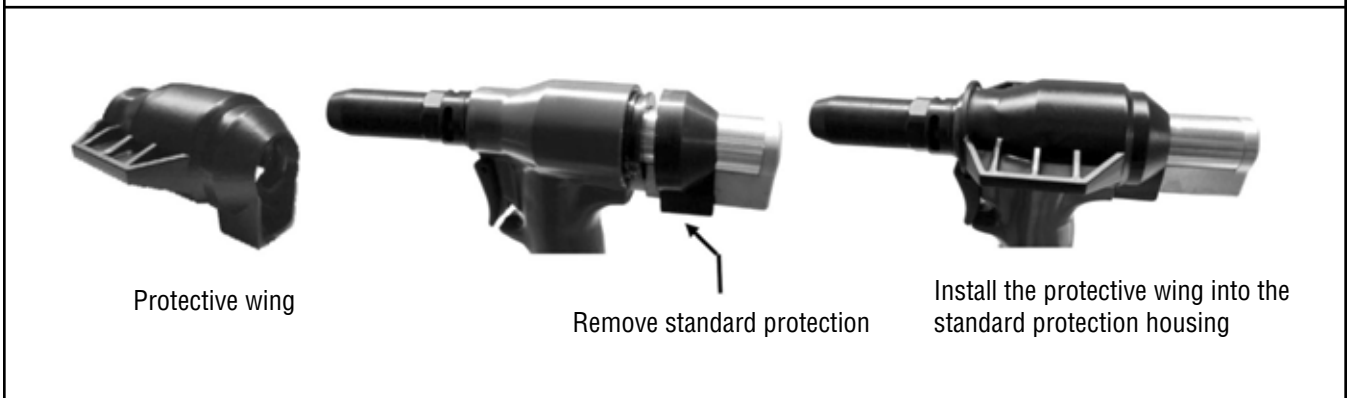

Together with the rubber base, it creates a support for the tool, avoiding any contact of the surface with the metal part of the tool body.

OPERATING SYSTEM

The hydro-pneumatic AE 938 tool, with oil pressure regulation, is designed to place female threaded inserts (from #4-40 to 3/8" / M3 to M10) and male threaded inserts (from #8-32 to 5/16" / M4 to M8). The hydro-pneumatic system and the mechanical components used inside the AE 938, when compared with other riveting tools, are more reliable. There is less wear and tear of the components, consequently the tool will last much longer and work better. The technical solutions adopted make the AE 938 more compact and lighter.

VIBRATION

When used correctly, the tool does not produce any dangerous vibration.

NOISE LEVEL

The tool is designed and manufactured in such a way that the noise level is very low. The weighed equivalent continuous acoustic pressure level A in the operator position is indeed below 80 dB (A). This information can allow the tool user to better evaluate the possible risks of danger.

TECHNICAL DATA

The following table provides the technical data and features of the tool, to which you must refer when contacting the ATLAS® Technical Assistance Department at PennEngineering.

TECHNICAL DATA AND FEATURES

AIR WORKING PRESSURE	87 PSI / 6 BAR
MAX AIR PRESSURE	70 to 100 PSI / 5 to 7 BAR
AIR CONSUMPTION PER CYCLE AT 6 BAR	5 liter
MAX STROKE	0.256" / 6.5 mm
MAX FORCE	19.000 N
MOTOR SPEED (SPIN ON)	1600 rpm
MOTOR SPEED (SPIN OFF)	2000 rpm
WEIGHT	4 lbs. / 1.8 kg
VIBRATIONS	< 2.5 m/s ²
NOISE LEVEL	76 dB (A)

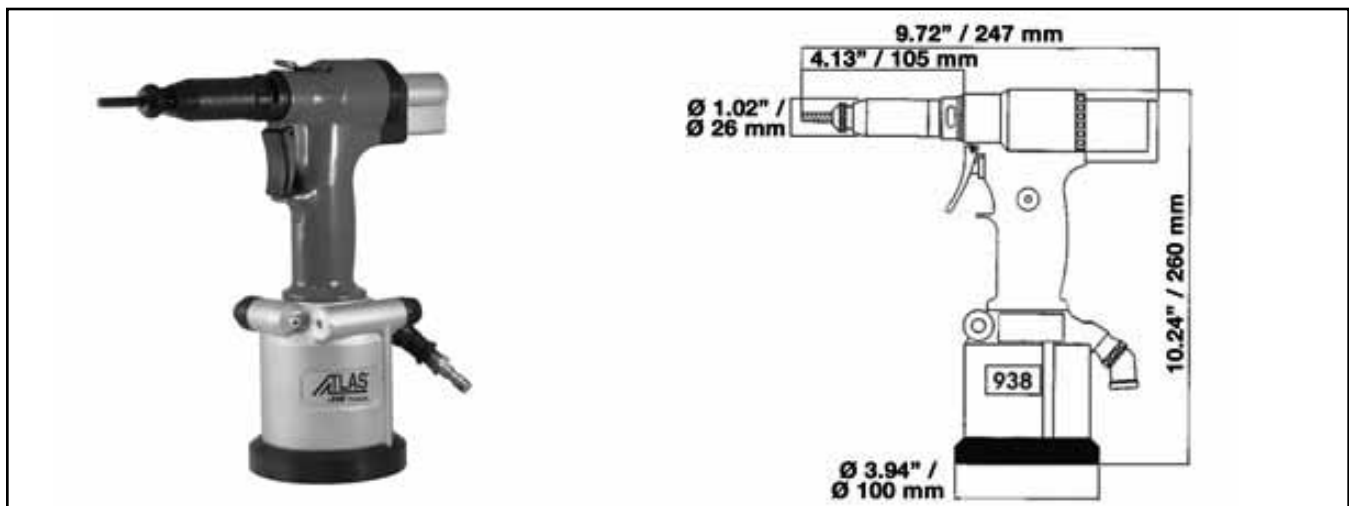

NOSE ASSEMBLIES AND STANDARD ACCESSORIES

The nose assemblies stated hereafter refers to standard tools.

Any special tool could consequently require special parts, different than those listed.

REF.	PART NUMBER	QTY	DESCRIPTION
1	4143400	1	RIV 938-HYDRO-PNEUMATIC TOOL FOR INSERTS (IN CASE)
2	3064400	1	HYDRAULIC OIL TYPE ISO VG 32 100CC
3	0369800	1	PLASTIC CASE
4	0207300	1	UNIVERSAL KEY
5	2533800	1	EMERGENCY AND STROKE REGULATION PIN
6	4154200	1	REGULATION WRENCH MM. 3,0
-	-	1	INSTRUCTION MANUAL

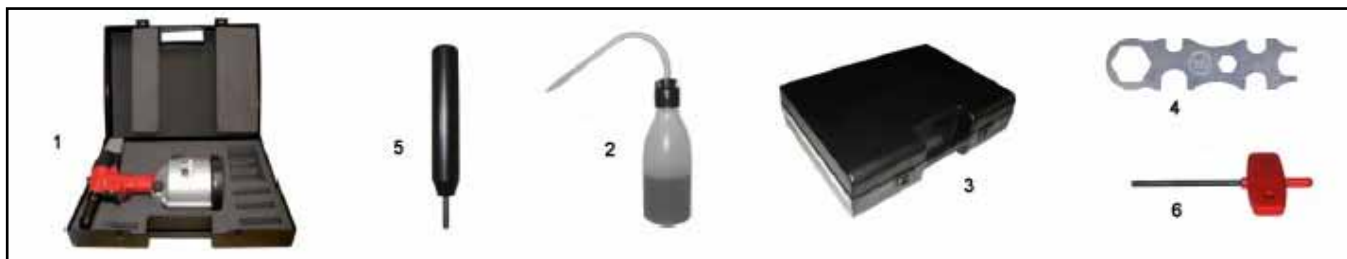

OPTIONAL TOOLING

For Blind Threaded Insert Installation



Description	Part Number For Complete Nose Assembly
Kit to install #4-40 blind threaded nuts	AE938NP-440
Kit to install #6-32 blind threaded nuts	AE938NP-632
Kit to install #8-32 blind threaded nuts	AE938NP-832
Kit to install #10-32 blind threaded nuts	AE938NP-1032
Kit to install 1/4-20 blind threaded nuts	AE938NP-2520
Kit to install 5/16-18 blind threaded nuts	AE938NP-3118
Kit to install 3/8-16 blind threaded nuts	AE938NP-3716
Kit to install M3 blind threaded nuts	AE938NP-M3
Kit to install M4 blind threaded nuts	AE938NP-M4
Kit to install M5 blind threaded nuts	AE938NP-M5
Kit to install M6 blind threaded nuts	AE938NP-M6
Kit to install M8 blind threaded nuts	AE938NP-M8
Kit to install M10 blind threaded nuts	AE938NP-M10



*Head ring nut can be ordered separately
Part number 0327700*

OPTIONAL TOOLING

For Blind Threaded Stud Installation



Description	Part Number For Complete Nose Assembly
Kit to install #8-32 blind threaded studs	AE938SNP-832
Kit to install #10-32 blind threaded studs	AE938SNP-1032
Kit to install 1/4-20 blind threaded studs	AE938SNP-2520
Kit to install 5/16-18 blind threaded studs	AE938SNP-3118
Kit to install M4 blind threaded studs	AE938SNP-M4
Kit to install M5 blind threaded studs	AE938SNP-M5
Kit to install M6 blind threaded studs	AE938SNP-M6
Kit to install M8 blind threaded studs	AE938SNP-M8



*Head ring nut can be ordered separately
Part number 0327700*

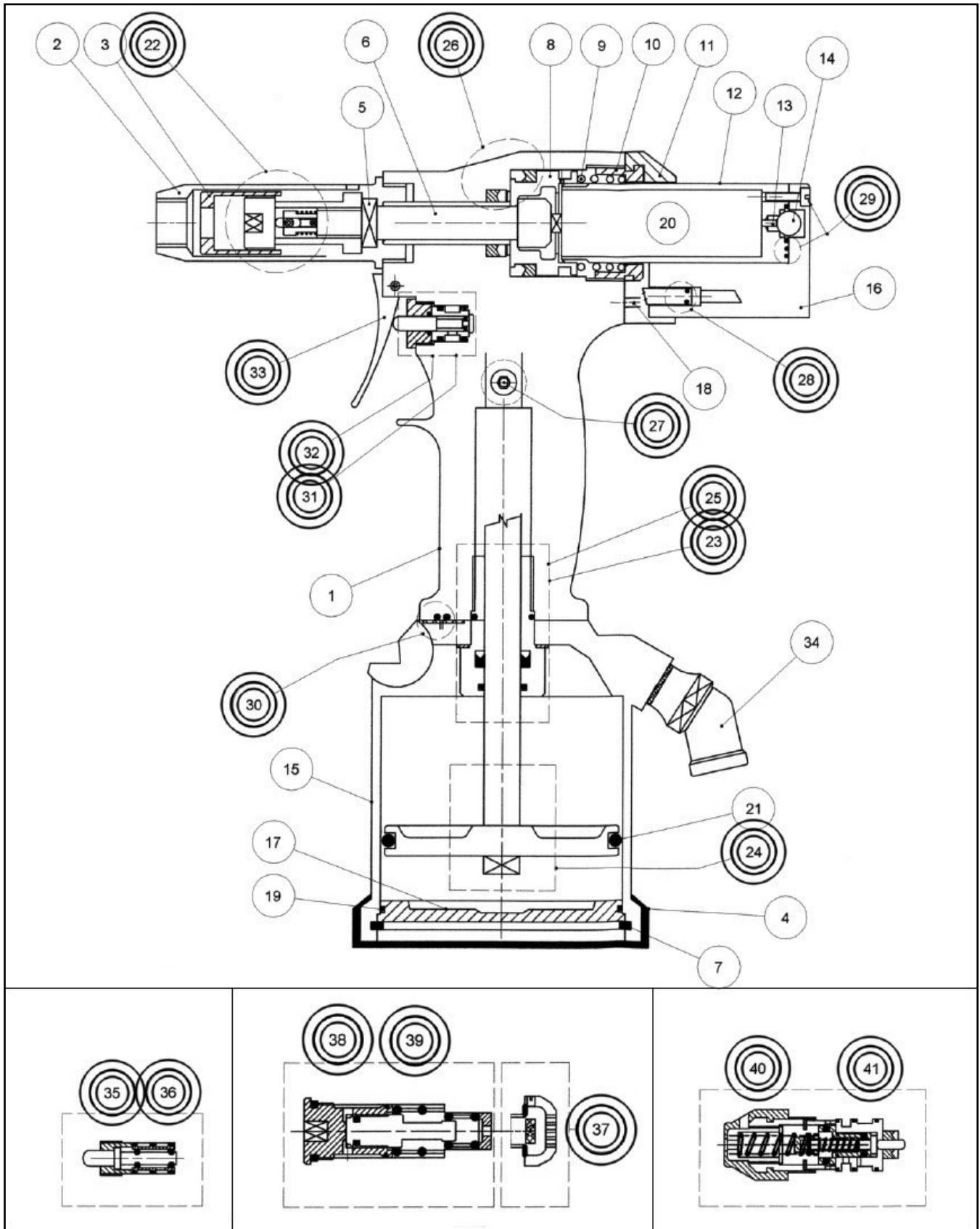

REF.	PART NUMBER	QTY	DESCRIPTION	REF.	PART NUMBER	QTY	DESCRIPTION
1	4153100	1	Handle casing	22	4174200	1	Quick coupling kit
2	3539900	1	Outer cone	23	4177400	1	Gasket kit (3 pieces)
3	4172400	1	Ring nut M3 - M10 / #4-40 - 3/8"	24	4152500	1	Piston, stem, O-ring kit (4 pieces)
4	4165100	1	Rubber base	25	4157300	1	Complete stem guide kit (5 pieces)
5	3098600	1	Ring nut	26	4151000	1	Piston gasket kit (2 pieces)
6	4151500	1	Rotating pin	27	4175700	1	Oil cap kit with washer
7	3093200	1	Snap ring	28	4175600	1	Air hoses kit with O-ring (6 pieces)
8	4151300	1	Oil piston	29	4151100	1	O-ring kit and screws (5 pieces)
9	4151700	1	Spring	30	4152300	1	Flat gasket kit and O-ring
10	4151800	1	Ring nut	31	4151200	1	O-ring kit (4 pieces)
11	4151900	1	Protection	32	4156900	1	Kit complete with O-ring (7 pieces)
12	3761500	1	Motor casing	33	4153400	1	Lever - pin kit
13	3761300	1	Rod	34	3542900	1	Connection thread 1/4" gas plus aluminum washer
14	3096900	1	Ball	35	4157000	1	Kit complete with O-ring (8 pieces)
15	4152800	1	Air body	36	4156600	1	O-ring kit (5 pieces)
16	4152000	1	Dispenser	37	4176600	1	Raffle kit (4 pieces)
17	3762300	1	Bottom	38	4155800	1	O-ring kit (7 pieces)
18	4152100	1	Pin	39	4157100	1	Kit complete with O-ring (13 pieces)
19	3762200	1	O-ring	40	4154400	1	Gasket kit (7 pieces)
20	3761000	1	Motor unit	41	4157200	1	Kit complete (18 pieces)
21	3235600	1	O-ring				

QUICK KIT

1

2

3

REF.	PART NUMBER	QTY	DESCRIPTION
1	4174200	1	Quick kit complete with spring
2	4176900	1	Quick kit with spring and without toothed ring nut
3	4172400	1	Toothed ring nut M3 - M10 / #4-40 - 3/8"

SPARE PARTS OF THE MOTOR UNIT (KIT 20)

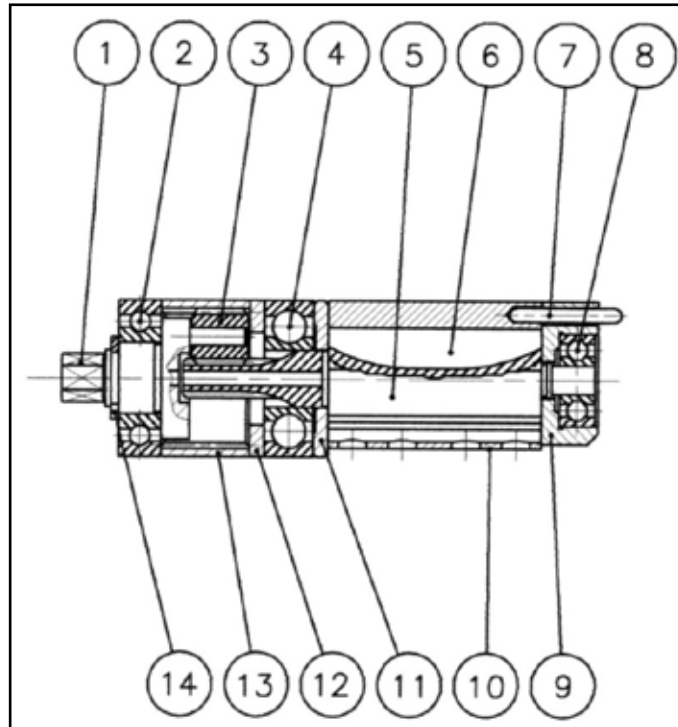

REF.	PART NUMBER	QTY	DESCRIPTION	REF.	PART NUMBER	QTY	DESCRIPTION
1	3763400	1	Planet wheel holder	22	3327300	1	Bearing
2	3763300	1	Bearing	23	3327400	1	Rear plate
3	3763200	1	Planet wheel	24	3327000	1	Stator
4	3327500	1	Bearing	25	3326900	1	Front plate
5	3523400	1	Rotor	26	3763700	1	Spacer
6	3327100	1	Fin	27	3763600	1	Crown wheel
7	3327200	1	Roller	28	3763500	1	Snap ring

ORDERING SPARE PARTS

Only local authorized dealers are allowed to repair the tool. Otherwise, contact the ATLAS® Technical Assistance Department of PennEngineering, where qualified engineers can help to solve any problems.

GENERAL WARNINGS

The operator must read carefully the information given in the present manual, especially with regard to the safety precautions listed in this chapter. The operator must also observe the warnings listed below:

- The tool shall be used exclusively by trained personnel.
- The tool and the work area shall be kept clean and tidy.
- The tool shall be rested upright on the rubber base on a flat surface to prevent it from falling.
- The tool shall only be used in normal operating conditions.
- The user shall wear suitable clothing taking care to avoid entanglement of loose parts, ties, long hair, cleaning rags etc. in the tool itself.
- When using the tool, the operator and others nearby should wear safety glasses to protect against fastener ejection. We also recommend wearing gloves when using the tool.
- The user shall use the accessories supplied when servicing and/or adjusting the tool.
- Unauthorized personnel shall not be allowed to touch the tool.
- Make sure that the air supply hoses are correctly sized.
- Do not drag the tool holding it by the hose when it is connected to the power supply. Keep the hose away from sources of heat and from sharp objects.
- Remember to remove service or adjustment keys after having making a repair and/or adjustment.
- Before disconnecting the compressed air hose from the tool, ensure it is not pressurized.
- Air supply must be disconnected before making tool repairs and cleaning.
- When filling with oil, only use fluids with the characteristics indicated herein.
- If you should accidentally spill oil on your skin, rinse and wash thoroughly with soap and water.
- Where possible, you are recommended to use a safety balance to support the tool.
- Pay attention to possible risk of whiplash with the air supply hoses.
- Do not operate the tool when it is directed towards anyone.

INTENDED USE

The tool is designed exclusively to be used with female threaded type inserts and male threaded studs with thread sizes M3 to M10 / #4-40 to 3/8”.

OPERATION

The tool shall not be used:

- In explosive or aggressive atmosphere or when there is an excessive amount of dust or oil in the air.
- In atmosphere subject to the risk of fire.
- When it is exposed to weather conditions.

RESIDUE RISK

During the normal working cycle and when servicing the tool, the operators are exposed to some residue risks which, due to the nature of the operations to be carried out, cannot be totally eliminated.

It is therefore absolutely crucial not to exceed the maximum pressure indicated in the technical data section on page 4.

HANDLING

The tool can be hand carried. It is recommended to store the tool in its case after using it. The tool can be transported safely if it has been correctly put away in its case.

Damages to the tool caused during transport and/or handling are not covered by WARRANTY. Repairs or replacements of damaged parts are at Customer's charge.

STORAGE

If you are not going to use the tool for a long time, you must put it away according to the following suggestions:

- Store the tool indoors.
- Protect the tool from impacts and stresses by keeping it in its case.
- Protect the tool from damp and excessive heat.
- Keep the tool away from corrosive substances.

CONNECTIONS

To avoid all sorts of problems when starting the tool you are recommended to observe the following:

PNEUMATIC

The pneumatic line is connected by a quick-release coupling hose to be attached to the air connection, thread size 1/4", supplied with the tool. The air supply hose must be flexible and must meet the safety requirements of the tool.

AIR SUPPLY

The air supply line must be free from dirt and damp to prevent the early wear of the moving components of the tool. Therefore, it is recommended to use dry air: i.e. not greased.

PRELIMINARY CHECKS

Before putting the tool into service you need to make a few inspections and checks in order to prevent errors or accidents while starting it.

- Check if the tool has been damaged during transportation.
- Check if the compressed air hose is accurately connected to the air supply line.
- Check if the tool turns freely and if the motor runs freely.

OPERATORS

The tool is designed to be used by one operator only.

Tool operators must satisfy the requirements stated hereafter (or they must be informed and trained accordingly).

They must be aware of the manual herein and of all information relevant to safety:

- They must have some general and technical education, to a sufficient level to be able to understand the manual and to interpret the drawings and the diagrams correctly.
- They must be acquainted with the safety rules, and with the industrial-safety and technical instructions.
- They must have an overall knowledge of the line and of the factory in which the tool is installed.
- They must know how to act in case of emergency, where to find the individual protection means and how to use them correctly.

Together with the above-mentioned requirements, the service technicians must also have appropriate technical training.

MOTOR SCREWING ROTATES NONSTOP

When the rotating pin (6 Part Number 4151500) is broken and you replace it, the motor may rotate continuously, which means that the shaft (19 Part Number 3761300) is too long; in this case it will have to be shortened by a few tenths to obtain the closure of the ball (14 Part Number 3096900).

MOTOR UNSCREWING DOES NOT ROTATE

Unlike the situation above, the shaft is too short and it has to be replaced with a new one, fitting it on the rotating pin (you will have to shorten it) in order to obtain the closure of the ball (14 Part Number 3096900).

TOOL PREPARATION AND SCREW REPLACEMENT

Warning:

Tool setting and screw replacement must be carried out with the tool disconnected from the air supply line.

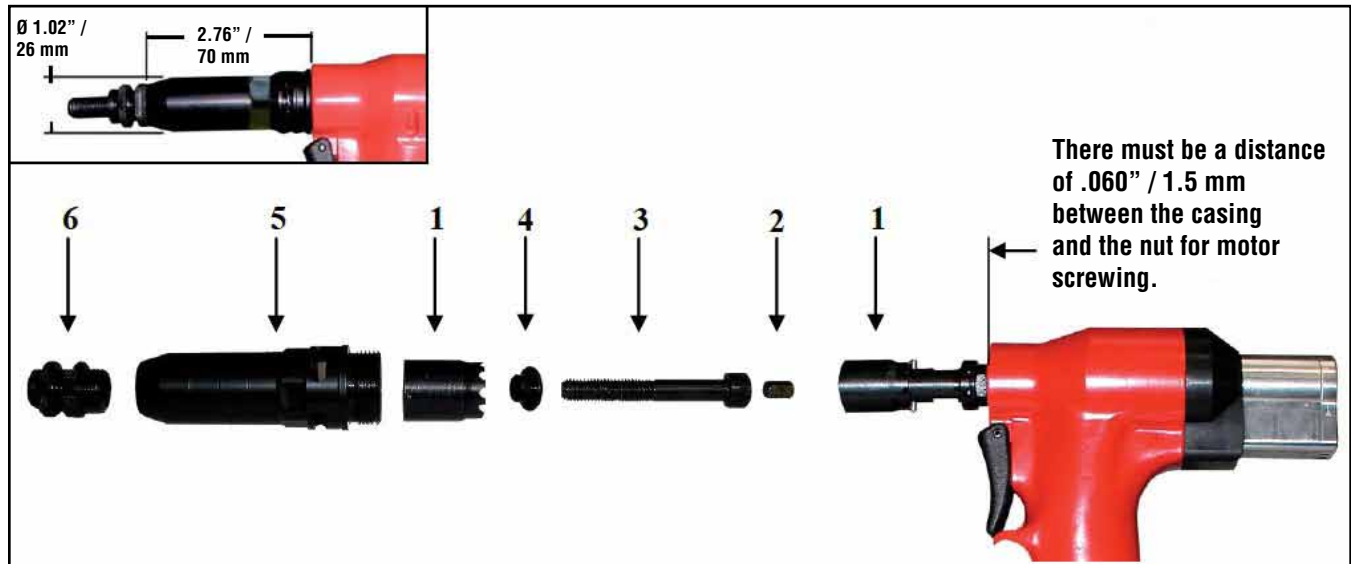

Note: *These instructions are relevant to KIT assembling and disassembling.*

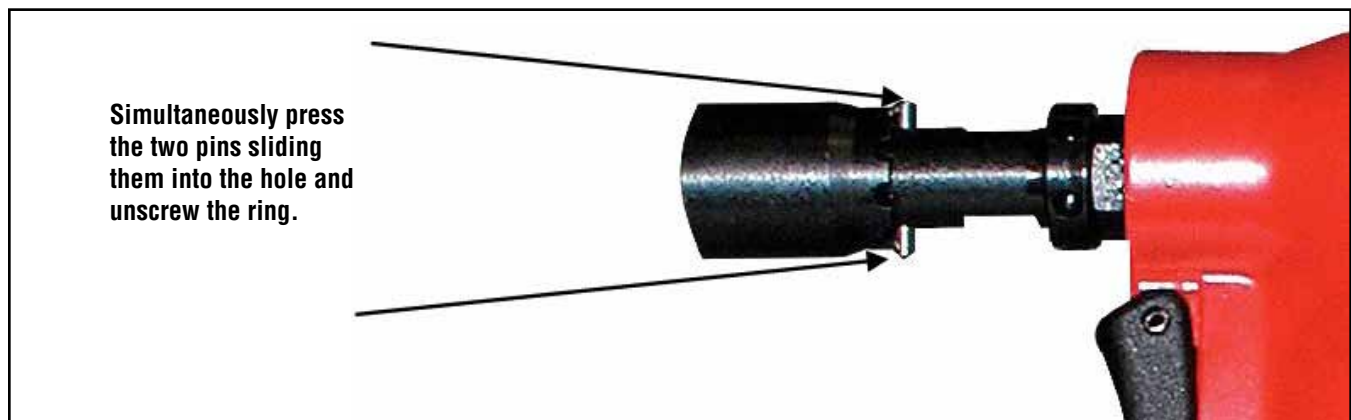

To replace screws you have to carry out the following operations:

Unscrew the toothed ring 1 from the tool. Insert joint 2. Insert screw 3. Insert screw adapter 4. Screw the toothed ring 1 making sure that the screw (or tie rod) moves freely, then try and find the most suitable joint (see indented ring). Screw on 5 and 6.



OIL (FORCE) PRESSURE REGULATION SETTINGS

M3 / #4-40 -	White
M3.5 / #6-32 -	White
M4 / #8-32 -	Yellow
M5 / #10-32 -	Yellow
M6 / 1/4-20 -	Orange
M8 / 5/16-18 -	Orange
M10 / 3/8-16 -	Orange

Note: *These settings are general guidelines to the operator. Inserts are not uniform as hardness and therefore some modifications may be necessary (+ or -).*

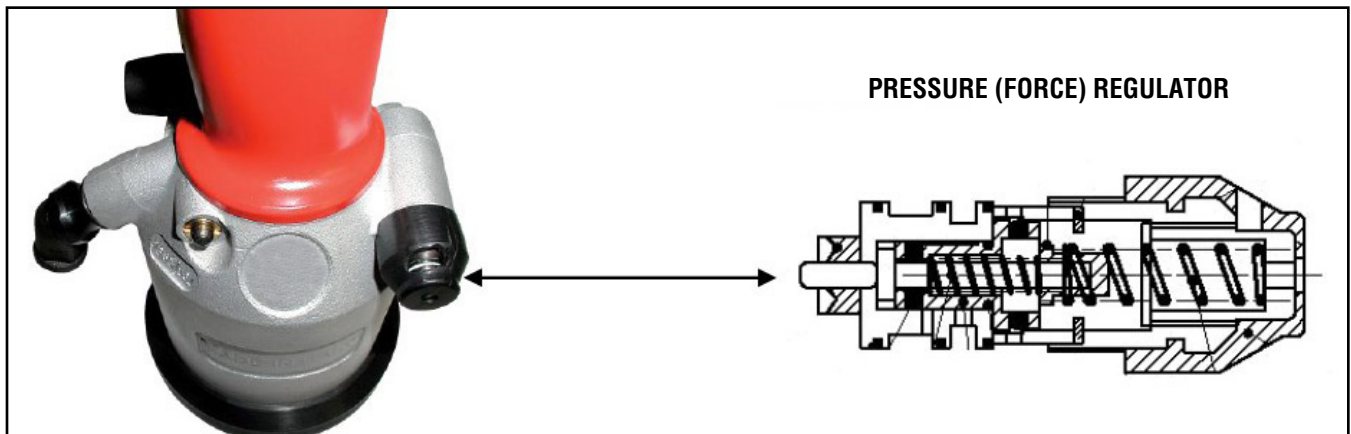
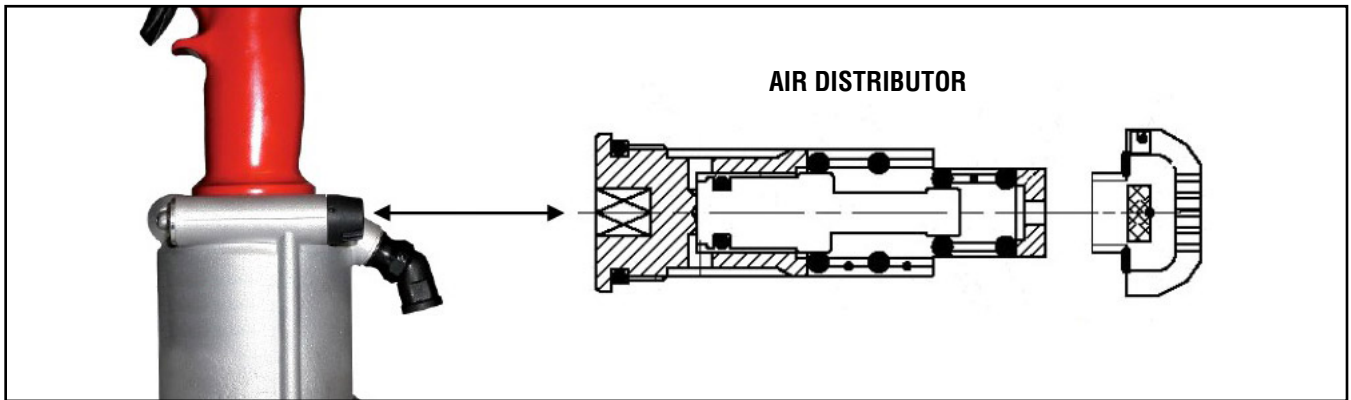
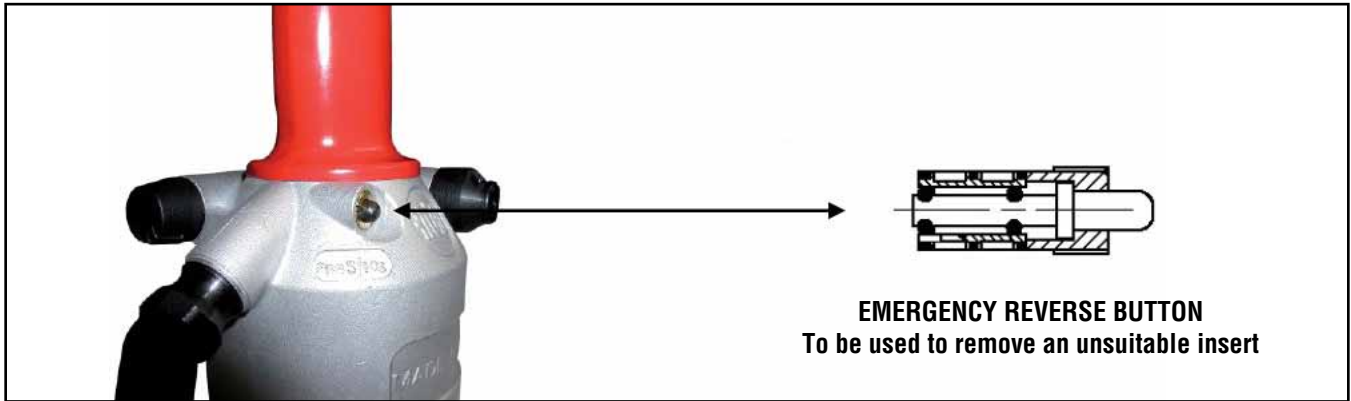
INFORMATION

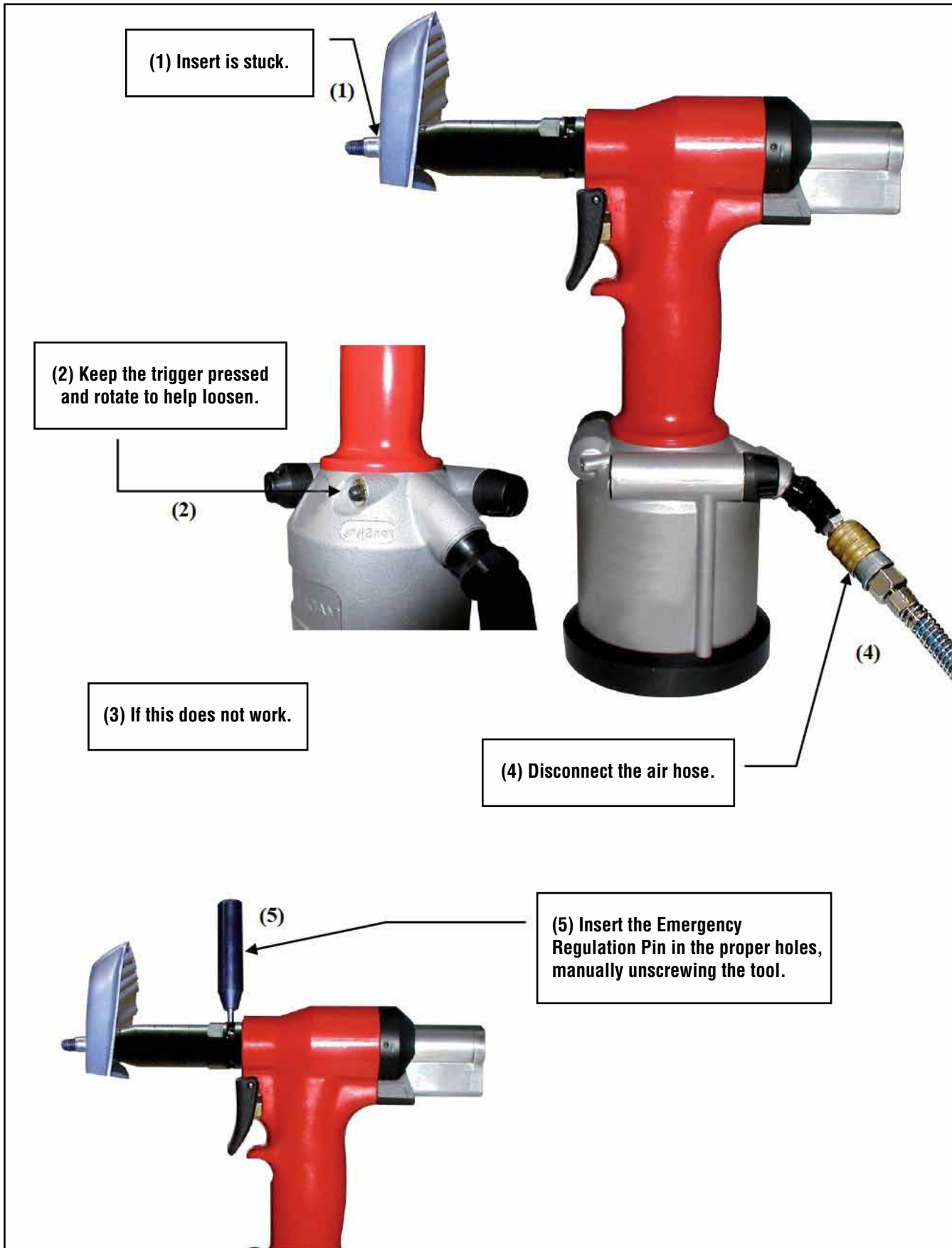



MAINTENANCE

Maintenance operations must be carried out with the tool stopped and disconnected from the pneumatic supply line.

Warnings:

- **The tool maintenance instructions must be followed carefully.**
- **To ensure safety and perfect tool efficiency, it is recommended to use exclusively ORIGINAL spare parts.**

CLEANING

It is a good rule to completely clean and grease the tool on a periodic basis (depending on the type and frequency of use). These operations must be carried out at least once a year.

Shut-off all sources of power to the tool.

The operator must wear and use suitable personal protections before starting to clean the tool.

ORDINARY MAINTENANCE

In order to prevent stoppages and faults of the tool, an ordinary maintenance (including inspections, checks and operations) must be scheduled to keep the following under systematic control:

- **State of lubrication of the tool.**
- **State of wear of consumable parts.**

REFILLING THE HYDRAULIC CIRCUIT WITH OIL

The hydraulic circuit needs to be refilled with oil after a continuous use, and when you notice a reduction in the tool stroke.

Proceed as follows (see photo at right):

- Disconnect the airline from the tool inlet.
- Remove cap together with relevant washer 27.
- Put the tool in horizontal position and slowly pour in the hydraulic oil (ISO VG 32 type) 50 until the circuit is full.
- Screw cap back on, together with relevant washer 27.
- Connect the tool to compressed air line and start up a couple of idle cycles. Stop pulling the trigger and slowly loosen screw 27; make sure that the circuit is full with oil and that no air bubbles are left inside.

Wear gloves when managing the oil.

Do not throw the old oil outdoors. Hand it over to an authorized waste disposal center.

Warning!: If you should accidentally spill oil on your skin, wash and rinse thoroughly with soap and water.



PARTS SUBJECT TO WEAR

On a periodic basis check the rubber base for wear, as this is what ensures the stability of the tool. If it should need replacing, order the spare base from PennEngineering indicating the year/serial number of the tool.

On a periodic basis check the screws and heads for wear and, if necessary, replace them as indicated (page 15).

FAULT DIAGNOSIS AND REPAIRS

REPAIRS

To ensure the operational efficiency and safety of the tool, all repair jobs shall be carried out exclusively by the local authorized dealer or by the Technical Assistance Service of PennEngineering.

REQUESTING ASSISTANCE

For any information concerning Use, Maintenance, Installation, Repair etc., PennEngineering is at the Customer's full disposal for all enquiries.

When making inquiries, the customer is requested to be absolutely clear and to always refer to this Manual.

DISMANTLING INSTRUCTIONS

DISMANTLING INSTRUCTIONS

When disposing the tool you need to separate the plastic parts, which are to be disposed of in compliance with current Regulations.

As for the bulk metal part of the tool, simply split-up the steel parts from those in other metals or alloys and send to be melted down and recycled.

The oil drained from the tool must not be thrown outdoors but handed over to an authorized oil disposal center.

ENCLOSED DOCUMENTS

DECLARATION

Declaration of Conformity to DIRECTIVE 2006/42/EC.

PennEngineering®



North America: Danboro, PA USA • E-mail: atlas@pemnet.com • Tel: +1-215-766-5987 • Fax: +1-215-766-5988 • 877-682-2505 (USA Only)

Europe: Galway, Ireland • E-mail: europe@pemnet.com • Tel: +353-91-751714 • Fax: +353-91-753541

Asia/Pacific: Singapore • E-mail: singapore@pemnet.com • Tel: +65-6-745-0660 • Fax: +65-6-745-2400

Shanghai, China • E-mail: china@pemnet.com • Tel: +86-21-5868-3688 • Fax: +86-21-5868-3988

Visit our PEMNET™ Resource Center at www.pemnet.com