

PennEngineering®

SPOTFAST® FASTENERS



BULLETIN

SF







SPOTFAST® FASTENERS

Allows permanent joining in metal to metal and metal to PCB/plastic panels

- Alternative to riveting and spot welding.
- No special installation equipment required.
- Flush or sub-flush on both sides.
- Minimal space requirements.
- No countersinking or other hole treatment required.
- Can be installed blind into bottom (panel 2) sheet.
- Can be concealed with paints and powder coatings.
- RoHS compliant.

Unlike rivets that “bulb” during installation, the ultimately flush profile of SpotFast® fasteners allows for unobtrusive attachment requiring minimal space. A smooth surface is retained for finishing and fasteners can be concealed easily with paints or powder coatings.

<p>Type SF fasteners create a permanent, flush joining of two sheets. Squeezing the fastener into place causes a cold-flow of panel material into the fastener's two separate clinch profiles. Type SF is designed for joining metal to metal. They install smooth with the top sheet, and flush or sub-flush with the bottom sheet. Fasteners can attach two metal sheets too difficult to weld; fasten sheets of unequal thicknesses; join dissimilar metals unable to be welded; and even attach ultra-thin metal sections.</p>	
<p>Type SFP fasteners offer the same benefits as Type SF but are made from precipitation hardened stainless steel for installation into stainless steel sheets.</p>	
<p>Type SFW fasteners offer the same benefits as Type SF but are specifically designed to allow pivoting of two sheets of metal. A wave washer provides the consistent torsion to allow repeatable rotation.</p>	
<p>Type SFK flush joining of metal to PCB/plastic panels</p>	



PART NUMBER DESIGNATION

SF	-	3	-	1.0	-	ZI
SFP	-	3	-	1.0	-	
SFW	-	3	-	1.0	-	LZ
SFK	-	3	-	1.0	-	ZI

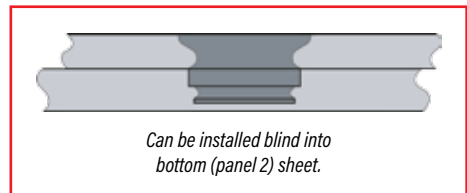
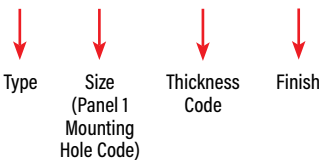

SPOTFAST® FASTENER SELECTOR GUIDE

Type	Primary Use				
	Joining two panels of similar or dissimilar metals	Joining two panels when one or more is stainless steel	Joining a metal panel to a PCB or plastic panel	Single point hinging applications	Offers highest corrosion resistance in product family
SF	▪			▪ (1)	
SFP	▪ (1)	▪		▪ (1)	▪
SFW	▪ (1)			▪	
SFK	▪ (1)		▪	▪ (1)	

(1) Not primary use.

METAL TO METAL



Type SF fastener installed into unequal thickness sheets. Fastener is smooth with top of panel 1.



Type SF fastener installed sub-flush with panel 2. Fastener will be flush at minimum sheet thickness.

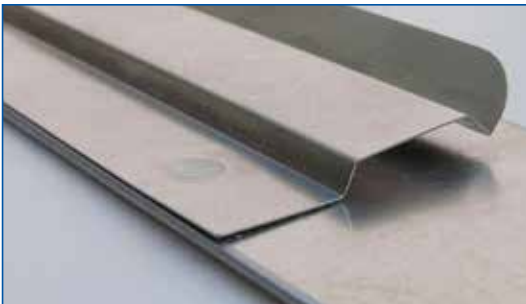

Sheets as thin as .005" / 0.13 mm may be attached to thicker sheets using a PEM® SpotFast® fastener. The thin sheet must be panel 1 and the "L" dimension must be equal to or less than the combined panel thicknesses. Consult our Applications Engineering department for more information.

HINGING APPLICATIONS



Type SFW fastener offers flush-mounted, smooth pivot point.

METAL TO PCB/PLASTIC

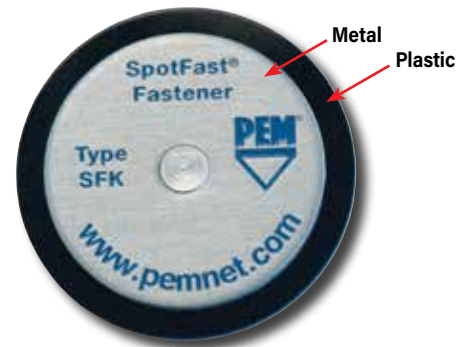

Type SFK fastener joining metal to plastic.

SPOTFAST® FASTENERS

TYPES SF AND SFP FOR PERMANENT JOINING OF TWO METAL SHEETS

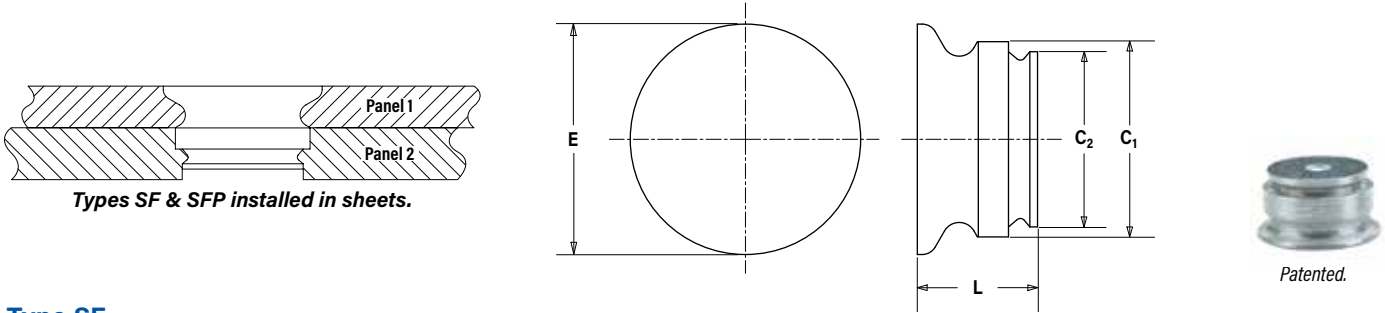

Type SF

Type and Size	Thickness Code	Panel 1				Panel 2				C ₁ Max.		C ₂ Max.		E Max.		L Max.		Min. Dist. Hole To Edge	
		Thickness ±0.08 mm / ±.003"		Mounting Hole +0.08 mm / +.003" -.000"		Thickness Min. (1)		Mounting Hole +0.08 mm / +.003" -.000"											
		mm	in.	mm	in.	mm	in.	mm	in.	mm	in.	mm	in.	mm	in.	mm	in.	mm	in.
SF-3	0.8	0.8	.031	3	.118	0.8	.031	2.5	.098	2.98	.117	2.48	.097	3.53	.139	1.5	.059	2.54	.1
SF-3	1.0	1	.039	3	.118	1	.039	2.5	.098	2.98	.117	2.48	.097	3.76	.148	1.9	.075	2.54	.1
SF-3	1.2	1.2	.047	3	.118	1.2	.047	2.5	.098	2.98	.117	2.48	.097	3.76	.148	2.31	.091	2.54	.1
SF-3	1.6	1.6	.063	3	.118	1.6	.063	2.5	.098	2.98	.117	2.48	.097	3.76	.148	3.12	.123	2.54	.1
SF-5	0.8	0.8	.031	5	.197	0.8	.031	4	.157	4.98	.196	3.97	.156	5.56	.219	1.5	.059	3.56	.14
SF-5	1.0	1	.039	5	.197	1	.039	4	.157	4.98	.196	3.97	.156	5.56	.219	1.9	.075	3.6	.14
SF-5	1.2	1.2	.047	5	.197	1.2	.047	4	.157	4.98	.196	3.97	.156	5.56	.219	2.31	.091	3.6	.14
SF-5	1.6	1.6	.063	5	.197	1.6	.063	4	.157	4.98	.196	3.97	.156	5.56	.219	3.12	.123	3.6	.14

Type SFP for Installation Into Stainless Steel Sheets

Type and Size	Thickness Code	Panel 1				Panel 2				C ₁ Max.		C ₂ Max.		E Max.		L Max.		Min. Dist. Hole To Edge	
		Thickness ±0.08 mm / ±.003"		Mounting Hole +0.08 mm / +.003" -.000"		Thickness Min. (1)		Mounting Hole +0.08 mm / +.003" -.000"											
		mm	in.	mm	in.	mm	in.	mm	in.	mm	in.	mm	in.	mm	in.	mm	in.	mm	in.
SFP-3	1.0	1	.039	3	.118	1	.039	2.5	.098	2.98	.117	2.48	.097	3.76	.148	1.9	.075	2.54	.1
SFP-3	1.2	1.2	.047	3	.118	1.2	.047	2.5	.098	2.98	.117	2.48	.097	3.76	.148	2.31	.091	2.54	.1
SFP-3	1.6	1.6	.063	3	.118	1.6	.063	2.5	.098	2.98	.117	2.48	.097	3.76	.148	3.12	.123	2.54	.1
SFP-5	1.0	1	.039	5	.197	1	.039	4.5	.177	4.98	.196	4.47	.176	5.56	.219	1.9	.075	3.6	.14
SFP-5	1.2	1.2	.047	5	.197	1.2	.047	4.5	.177	4.98	.196	4.47	.176	5.56	.219	2.31	.091	3.6	.14
SFP-5	1.6	1.6	.063	5	.197	1.6	.063	4.5	.177	4.98	.196	4.47	.176	5.56	.219	3.12	.123	3.6	.14

(1) Fastener will provide flush application at minimum sheet thickness.

SPOTFAST® FASTENERS

TYPE SFW WITH WAVE WASHER FOR SINGLE POINT HINGING APPLICATIONS

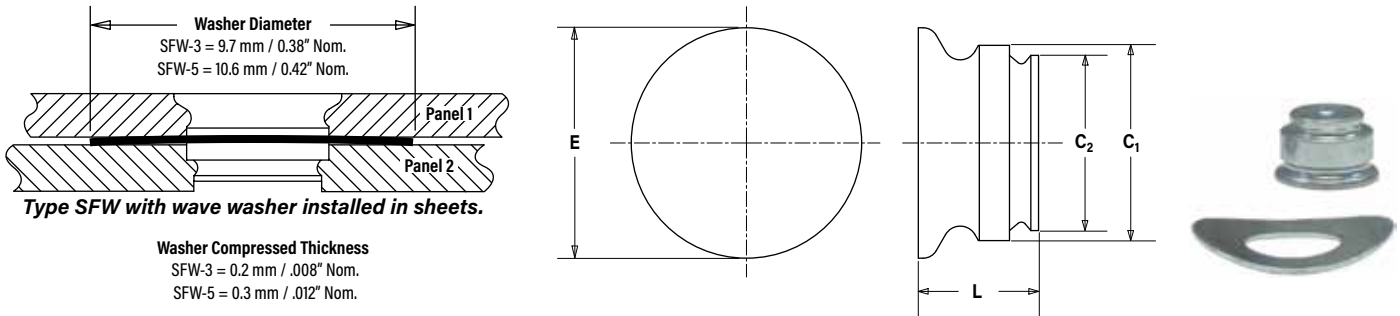

Type and Size (2)	Thickness Code	Panel 1				Panel 2				C ₁ Max.		C ₂ Max.		E Max.		L Max.		Min. Dist. Hole \varnothing To Edge	
		Thickness ± 0.08 mm / $\pm .003$ "		Mounting Hole $+0.08$ mm / $+ .003$ " $- .000$ "		Thickness Min. (1)		Mounting Hole $+0.08$ mm / $+ .003$ " $- .000$ "											
		mm	in.	mm	in.	mm	in.	mm	in.	mm	in.	mm	in.	mm	in.	mm	in.	mm	in.
SFW-3	0.8	0.8	.031	3	.118	0.8	.031	2.5	.098	2.98	.117	2.48	.097	3.53	.139	2.09	.082	2.54	.1
SFW-3	1.0	1	.039	3	.118	1	.039	2.5	.098	2.98	.117	2.48	.097	3.76	.148	2.49	.098	2.54	.1
SFW-3	1.2	1.2	.047	3	.118	1.2	.047	2.5	.098	2.98	.117	2.48	.097	3.76	.148	2.90	.114	2.54	.1
SFW-3	1.6	1.6	.063	3	.118	1.6	.063	2.5	.098	2.98	.117	2.48	.097	3.76	.148	3.71	.146	2.54	.1
SFW-5	0.8	0.8	.031	5	.197	0.8	.031	4	.157	4.98	.196	3.97	.156	5.56	.219	1.98	.078	3.6	.14
SFW-5	1.0	1	.039	5	.197	1	.039	4	.157	4.98	.196	3.97	.156	5.56	.219	2.39	.094	3.6	.14
SFW-5	1.2	1.2	.047	5	.197	1.2	.047	4	.157	4.98	.196	3.97	.156	5.56	.219	2.79	.110	3.6	.14
SFW-5	1.6	1.6	.063	5	.197	1.6	.063	4	.157	4.98	.196	3.97	.156	5.56	.219	3.61	.142	3.6	.14

(1) Fastener will provide flush application at minimum sheet thickness. (2) Type SFW fasteners are shipped with mating washers.

TYPE SFK FOR JOINING METAL TO PCB/PLASTIC PANELS

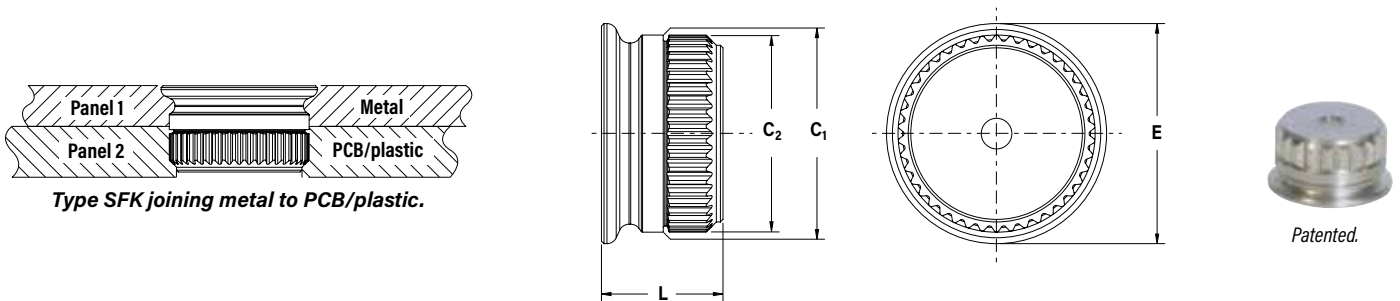

Type and Size	Thickness Code	Panel 1				Panel 2				C ₁ Max.		C ₂ ± 0.08 mm / $\pm .003$ "		E Max.		L Max.		Min. Dist. Hole \varnothing To Edge	
		Thickness ± 0.08 mm / $\pm .003$ "		Mounting Hole $+0.08$ mm / $+ .003$ " $- .000$ "		Thickness Min. (1)		Mounting Hole $+0.08$ mm / $+ .003$ " $- .000$ "											
		mm	in.	mm	in.	mm	in.	mm	in.	mm	in.	mm	in.	mm	in.	mm	in.	mm	in.
SFK-3	0.8	0.8	.031	3	.118	1.6	.063	2.5	.098	2.98	.117	2.9	.114	3.53	.139	2.31	.091	3	0.12
SFK-3	1.0	1	.039	3	.118	1.6	.063	2.5	.098	2.98	.117	2.9	.114	3.76	.148	2.51	.099	3	0.12
SFK-3	1.2	1.2	.047	3	.118	1.6	.063	2.5	.098	2.98	.117	2.9	.114	3.76	.148	2.72	.107	3	0.12
SFK-3	1.6	1.6	.063	3	.118	1.6	.063	2.5	.098	2.98	.117	2.9	.114	3.76	.148	3.12	.123	3	0.12
SFK-5	0.8	0.8	.031	5	.197	1.6	.063	4.5	.177	4.98	.196	4.9	.193	5.56	.219	2.31	.091	5.1	0.20
SFK-5	1.0	1	.039	5	.197	1.6	.063	4.5	.177	4.98	.196	4.9	.193	5.56	.219	2.51	.099	5.1	0.20
SFK-5	1.2	1.2	.047	5	.197	1.6	.063	4.5	.177	4.98	.196	4.9	.193	5.56	.219	2.72	.107	5.1	0.20
SFK-5	1.6	1.6	.063	5	.197	1.6	.063	4.5	.177	4.98	.196	4.9	.193	5.56	.219	3.12	.123	5.1	0.20

(1) Fastener will provide flush application at minimum sheet thickness.



MATERIAL AND FINISH SPECIFICATIONS

Type	Fastener Materials		Standard Finishes			For Use in Sheet Hardness: (2)	
	Hardened Carbon Steel	Precipitation Hardening Grade Stainless Steel	Passivated and/or Tested Per ASTM A380	Zinc Plated, 5µm, Colorless (1)	Zinc Plated, 5µm, Colorless with Lubricant (1)	HRB 80 / HB 150 or Less	HRB 88 / HB 183 or Less
SF	▪			▪		▪	
SFP		▪	▪				▪
SFW	▪			(Washer)	▪ (Fastener)	▪	
SFK	▪			▪		▪	
Part Number Code For Finishes		None	ZI	LZ			

(1) See PEM Technical Support section of our web site for related plating standards and specifications.

(2) HRB - Hardness Rockwell "B" Scale. HB - Hardness Brinell.

INSTALLATION

TYPE SF AND SFP

- Step 1.** Prepare properly sized mounting hole in both panels. Do not perform any secondary operations such as deburring. If the hole is punched, be sure to install fastener into punched side of hole.
- Step 2.** Place Panel 2 with smaller mounting hole on anvil and align Panel 1 mounting hole with the mounting hole of Panel 2. Place the smaller diameter end of the fastener through the mounting holes as shown in the drawing to the right. (See figure SF-1).
- Step 3.** With the punch and anvil surfaces parallel, apply squeezing force until the fastener is flush with the top of Panel 1. (See figure SF-1).

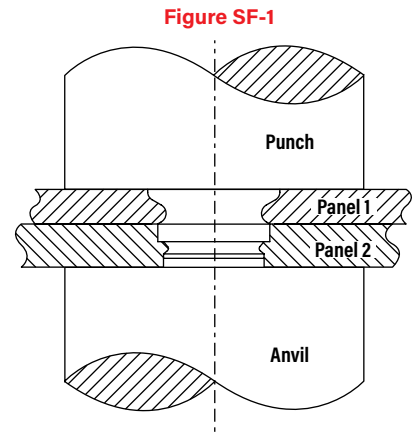

NOTE: To use Type SF or SFP as a flush-mounted pivot point, for best results, install SpotFast fastener into Panel 1 first, then place Panel 2 over fastener and squeeze again.

PEMSERTER® Installation Tooling

Size	Punch Part No.	Anvil Part No.
SF-3 / SF-5	975200048	975200046

TYPE SFW

- Step 1.** Prepare properly sized mounting hole in both panels. Do not perform any secondary operations such as deburring. If the hole is punched, be sure to install fastener into punched side of hole.
- Step 2.** Using only Panel 1, with the punch and anvil surfaces parallel, apply squeezing force until the fastener is flush with the top of Panel 1. (See figure SFW-1).
- Step 3.** To ensure proper function of washer, place washer over installed fastener (concave side facing up), then place Panel 2 over fastener. Apply squeezing force. Keep gap between Panel 2 and anvil. (See "G" in figure SFW-2).

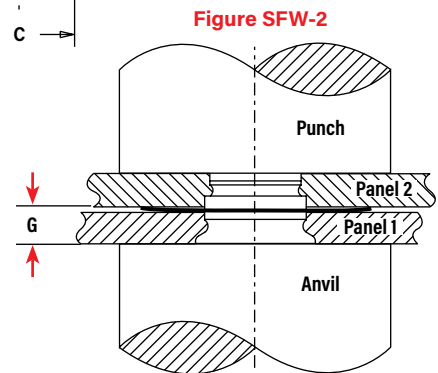
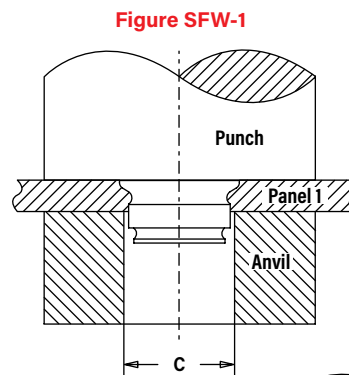

PEMSERTER® Installation Tooling

Size	C +0.08/+0.003 (mm) / (in.)	Punch Part No.	Part Number For Anvil Used In Step 2	Part Number For Anvil Used In Step 3
SFW-3	3.05 / .120	975200048	970200229300	975200046
SFW-5	5.05 / .199	975200048	970200020300	975200046

Size	G (mm) / (in.)
SFW-3-0.8	1.09-1.25 / .043-.049
SFW-5-0.8	1.3-1.44 / .051-.057
SFW-3-1.0	1.5-1.65 / .059-.065
SFW-5-1.0	1.91-2.06 / .075-.081

INSTALLATION

TYPE SFK

- Step 1.** Prepare properly sized mounting hole in both panels. Do not perform any secondary operations such as deburring. If the hole is punched, be sure to install fastener into punched side of hole.
- Step 2.** Using only Panel 1, with the punch and anvil surfaces parallel, apply squeezing force until the fastener is flush with the top of Panel 1. (See figure SFK-1).
- Step 3.** Place Panel 2 over fastener and apply squeezing force. (See figure SFK-2).

Figure SFK-1

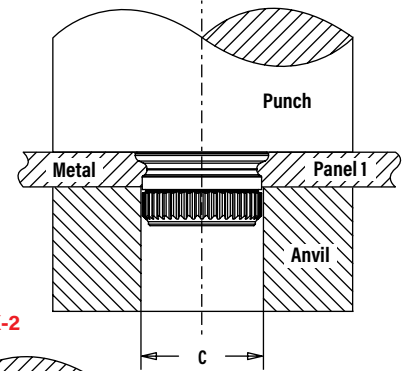
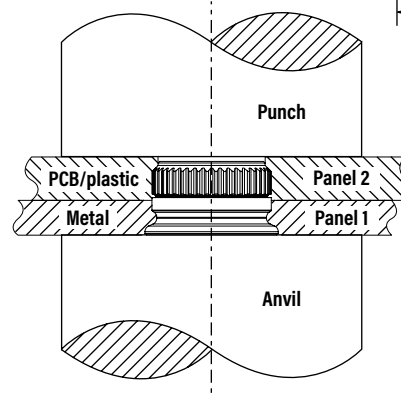

Figure SFK-2



PEMSERTER® Installation Tooling

Size	C +0.08/+0.003 (mm) / (.in.)	Punch Part No.	Part Number For Anvil Used In Step 2	Part Number For Anvil Used In Step 3
SFW-3	3.05 / .120	975200048	970200229300	975200046
SFW-5	5.05 / .199	975200048	970200020300	975200046

PERFORMANCE DATA⁽¹⁾

TYPE SF

Type and Size	Thickness Code	Installation				Pushout of Panel 2 ⁽²⁾			
		Cold-rolled Steel		Aluminum		Cold-rolled Steel		Aluminum	
		kN	lbs.	kN	lbs.	N	lbs.	N	lbs.
SF-3	0.8	8	1800	6	1350	360	80	200	45
SF-3	1.0	9	2025	6.5	1475	525	115	250	55
SF-3	1.2	11	2475	7	1575	555	125	310	70
SF-3	1.6	13	2925	7.5	1700	920	205	550	125
SF-5	0.8	11	2475	8	1800	625	140	310	70
SF-5	1.0	12	2700	9.5	2150	800	180	515	115
SF-5	1.2	18	4050	10	2250	1200	270	770	170
SF-5	1.6	20	4500	12.5	2825	1500	335	1145	255

TYPE SFP

Type and Size	Thickness Code	Stainless Steel			
		Installation		Pushout of Panel 2 ⁽²⁾	
		kN	lbs.	N	lbs.
SFP-3	1.0	13.5	3000	620	140
SFP-3	1.2	20	4500	830	186
SFP-3	1.6	22	5000	1500	340
SFP-5	1.0	18	4000	990	222
SFP-5	1.2	27	6000	1158	260
SFP-5	1.6	33	7500	3117	701

(1) Published installation forces are for general reference. Actual set-up and confirmation of complete installation should be made by observing proper seating of fastener as described in the installation steps. Other performance values reported are averages when all proper installation parameters and procedures are followed. Variations in mounting hole size, sheet material, and installation procedure may affect performance. Performance testing this product in your application is recommended. We will be happy to provide technical assistance and/or samples for this purpose.

(2) In most applications, pullout strength of the SpotFast fastener in Panel 1 exceeds pushout strength of Panel 2.

SPOTFAST® FASTENERS

PERFORMANCE DATA⁽¹⁾

TYPE SFW

Type and Size	Thickness Code	Installation into Panel 1				Installation into Panel 2				Pushout of Panel 2 ⁽²⁾			
		Cold-rolled Steel		Aluminum		Cold-rolled Steel		Aluminum		Cold-rolled Steel		Aluminum	
		kN	lbs.	kN	lbs.	kN	lbs.	kN	lbs.	N	lbs.	N	lbs.
SFW-3	0.8	4.5	1010	2.5	560	3	675	2	450	350	78	85	19
SFW-3	1.0	5.5	1240	3.5	780	4.5	1010	2	450	375	84	140	31
SFW-3	1.2	6	1350	3.5	780	5	1125	2	450	500	112	250	56
SFW-3	1.6	7	1575	4	900	6	1350	2.5	560	780	175	340	76
SFW-5	0.8	7	1575	3.5	780	8	1800	4	900	350	78	270	61
SFW-5	1.0	7	1575	3.5	780	8.5	1910	5	1125	380	153	425	96
SFW-5	1.2	7	1575	4	900	8.5	1910	5	1125	925	208	510	115
SFW-5	1.6	9	2025	5	1125	10	2250	5	1125	1450	326	600	135

TYPE SFK

Type and Size	Thickness Code	Installation into Panel 1		Installation into Panel 2		Pushout of Panel 2 ⁽²⁾	
		Cold-rolled Steel		FR-4 Fiberglass		N	lbs.
		kN	lbs.	kN	lbs.		
SFK-3	0.8	6.2	1400	1.8	400	200	45
SFK-3	1.0	8	1800	1.8	400	200	45
SFK-3	1.2	8.9	2000	1.8	400	200	45
SFK-3	1.6	10.2	2300	1.8	400	200	45
SFK-5	0.8	11.1	2500	1.8	400	400	90
SFK-5	1.0	13.5	3000	1.8	400	400	90
SFK-5	1.2	15.6	3500	1.8	400	400	90
SFK-5	1.6	17.8	4000	1.8	400	400	90

(1) Published installation forces are for general reference. Actual set-up and confirmation of complete installation should be made by observing proper seating of fastener as described in the installation steps. Other performance values reported are averages when all proper installation parameters and procedures are followed. Variations in mounting hole size, sheet material, and installation procedure may affect performance. Performance testing this product in your application is recommended. We will be happy to provide technical assistance and/or samples for this purpose.

(2) In most applications, pullout strength of the SpotFast fastener in Panel 1 exceeds pushout strength of Panel 2.



Regulatory compliance information is available in Technical Support section of our website. © 2015 PennEngineering.

Specifications subject to change without notice. See our website for the most current version of this bulletin.

PennEngineering®



North America: Danboro, PA USA • E-mail: info@pemnet.com • Tel: +1-215-766-8853 • Fax: +1-215-766-0143 • 800-237-4736 (USA Only)
Europe: Galway, Ireland • E-mail: europe@pemnet.com • Tel: +353-91-751714 • Fax: +353-91-753541
Asia/Pacific: Singapore • E-mail: singapore@pemnet.com • Tel: +65-6-745-0660 • Fax: +65-6-745-2400
 Shanghai, China • E-mail: china@pemnet.com • Tel: +86-21-5868-3688 • Fax: +86-21-5868-3988

Visit our PEMNET™ Resource Center at www.pemnet.com

Technical support e-mail: techsupport@pemnet.com