

Fastener Length Monitoring (FLM) System Option

The PEMSERTER® Fastener Length Monitoring (FLM) System attaches to a Series 2000® automatic feed press and verifies the lengths of the studs and standoffs being installed. The FLM system will flag and reject a fastener that does not meet the length criteria initially designated during setup by the operator. The systems photoelectric sensors can identify a fastener's length within 1/16" or 2mm.

The Series 2000 software easily guides the operator through setup and use of the FLM system. Only proper length fasteners will be installed. If a fastener is rejected, the operator is notified and the system seeks a part of the correct length.

The FLM system can eliminate errors and reduce costs due to incorrect part loading or in-house mixed part situations.

FLM Software is available on all new PEMSERTER Series 2000 presses. Some recent models can also be retrofitted. Call us to find out more.



PEMSERTER®

How to Order Components for the FLM System

▶ 8006400 FLM sensor package

The sensor package consists of the following:

1. The sensing unit body and cover.
2. Sensors and hardware.
3. Quick connect cable and plug.
4. Acrylic cover.

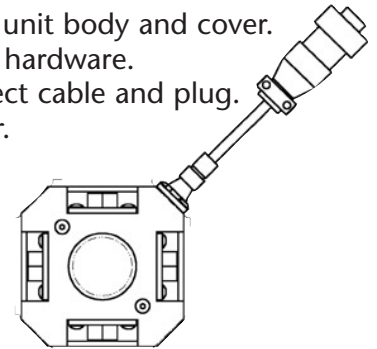

▶ 8006401 (small adapter) or 8006402 (large adapter)

Each adapter consists of the following:

1. One adapter, large or small.
2. Two pair of anti-vibration proof washers.
3. Two Lock-nuts.

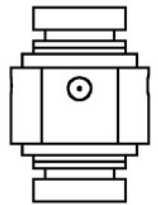

Adapters are installed at our factory. They can also be changed in the field.

▶ See Part No. List for FLM chambers

Each chamber is designed for the entire range of lengths of a specific size fastener.

The chambers are designed to fit onto existing PEMSERTER shuttle tooling.



Fastener Length Monitoring (FLM) System

Part Number	Description	Required
8006400	Sensor package	1 for each press
8006401	Small adapter for FH-M2.5 to HFH-032/M5	1 for smaller fasteners and/or 1 for larger fasteners
8006402	Large adapter for FH-0420/M6 to HFH-0518/M8	
Stud Shuttle Chambers:		
8006403	FH-M2.5	Small
8006404	FH 440/M3	Small
8006405	FH-632/M3.5	Small
8006406	FH-832/M4	Small
8006407	FH-032/M5	Small
8006408	FH-0420/M6	Small
8006409	FH-0518/M8	Large
8006410	HFH-032/M5	Small
8006411	HFH-0420/M6	Small
8006412	HFH-0518/M8	Large
8006635	SO-440/M3	Small
8006636	SO-632/M3.5	Small
8006637	SO-832/032/M4/M5	Large
8006638	FHL-M2.5	Small
8006639	FHL-M3	Small
8006745	FHL-M4	Small
8006958	HFE-042/M6	Large

1 for each size of fastener.
Assembles on to PEMSERTER automatic stud-type feeding shuttle, in place of existing chamber.

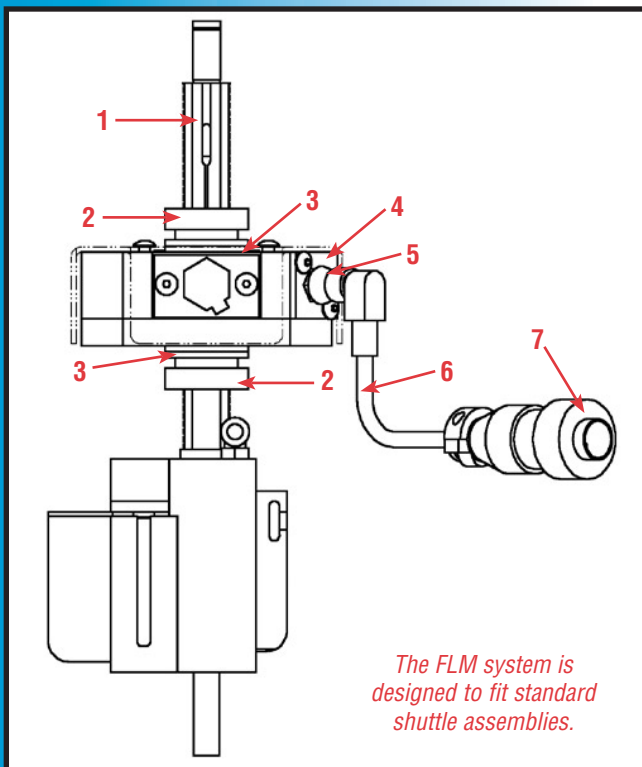

1. Threaded chamber for fastener length monitoring is available in large or small size to accommodate fastener thread size.
2. Lock-nuts, top and bottom, adjust the position of the sensing unit to accommodate the dash length of the fastener.
3. Two pair of anti-vibration washers, lock the sensing unit securely in place.
4. Acrylic cover protects sensors.
5. Sensing unit center adapter can be changed to accommodate large or small chamber.
6. Quick connect cable.
7. Stud-in-sensor plug connects to the existing terminal on PEMSERTER Series 2000 press.

PennEngineering®

www.pemnet.com