

PEM SERTER[®] SERIES 2000[®]

AUTOMATIC INSERTION PRESS

The **PEMSERTER[®] Series 2000[®] automatic fastener-installation press system** incorporates upgraded operating features and expansion capabilities to promote streamlined job productivity and quality. The press offers the ideal technology to install all types of self-clinching fasteners rapidly, reliably, and permanently in thin-metal sheets.

Features and Benefits

- ▶ The job search and recall mode allows operators to reference 300 stored jobs and return to previous jobs quickly and easily.
- ▶ PLC readily accommodates custom programs.
- ▶ A cast aluminum bowl with epoxy coating handles larger parts and performs quietly.
- ▶ A wide feeder track increases fastener-feeding rates; the robust shuttle support design improves small-fastener feeding.
- ▶ A larger touch-screen and graphics contribute to operator-friendly operation.
- ▶ The press is Ethernet capable and expandable to interface with data collection systems, production management systems, and off-site troubleshooting systems.
- ▶ Adjustable ram stroke distance control in manual and bottom feed nut mode.
- ▶ Real-time installation force feedback displayed on screen.
- ▶ Fastener and batch counters.
- ▶ Descriptive screen alerts for operating errors.
- ▶ Smart dwell and force verification.
- ▶ Self-diagnostic system lets operator work with increased speed, accuracy, and confidence.
- ▶ LightStream[®] Operator Safety System provides continuous operator and workpiece protection.
- ▶ Color-coded tooling for quick changeover.



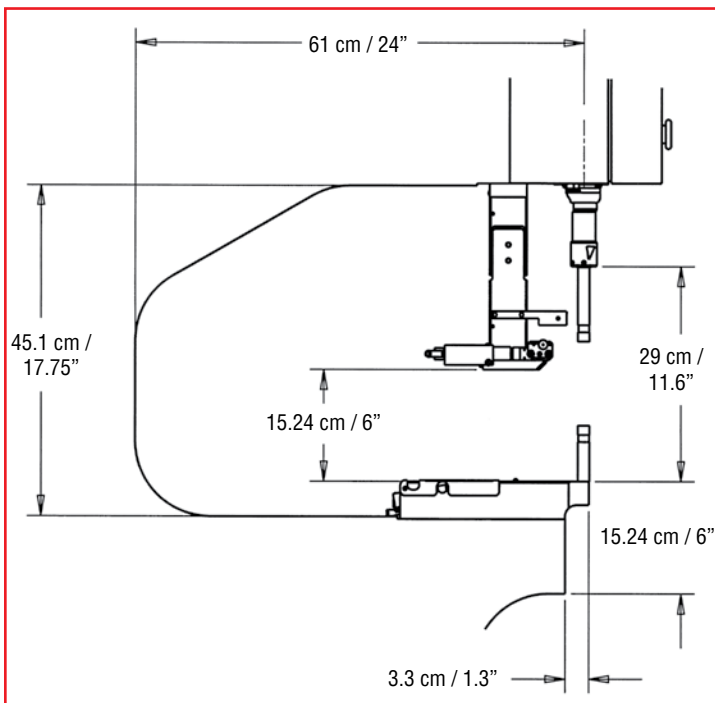

Specifications

Ram Force 1.8 to 71.2 kN / 400 to 16,000 lbs.

Pressure System Type Air-Over-Oil

Electric Requirements 120V 60Hz 4A or
230V 50Hz 2A single phase

Air Requirements* 6 to 7 BAR / 90 to 100 PSI
12 mm / 1/2" dia. minimum line flow

Throat Depth 61 cm / 24"

Height 193 cm / 76"

Width 92 cm / 36"

Depth 126 cm / 49.5"

Weight 1,135 kg / 2,500 lbs.

*1 psi = 0.07 bar. 1 bar = 14.5 psi.

The Series 2000 press utilizes a programmable logic controller and a menu-driven touch screen operator interface system, in eleven available languages. Touch screens allow for quick-run-set-up, easy operator training, and precise fastener installation setups. They also allow the operator to instantly adjust installation variables such as dwell time and installation force and automatically alert and direct the operator to any safety or system faults for quick diagnosis.



The Series 2000 press has a unique patented LightStream® Operator Safety System. It is a wireless, fail-safe system which utilizes a pair of infrared beams that immediately detect when the main ram contacts any object, metallic or non-metallic, that should not be in its path. The LightStream system provides a fast, precise, and reliable safety system that ensures ram force is only applied to fasteners during installation.



Specifications subject to change without notice.
Check our website for the most current version of this bulletin.

© 2008, PennEngineering

PennEngineering®



North America: Danboro, PA USA • E-mail: info@pemnet.com • Tel: +1-215-766-8853 • Fax: +1-215-766-0143 • 800-237-4736 (USA Only)

Europe: Galway, Ireland • E-mail: europe@pemnet.com • Tel: +353-91-751714 • Fax: +353-91-753541

Asia/Pacific: Singapore • E-mail: singapore@pemnet.com • Tel: +65-6-745-0660 • Fax: +65-6-745-2400
Shanghai, China • E-mail: china@pemnet.com • Tel: +86-21-5868-3688 • Fax: +86-21-5868-3988

Visit our PEMNET™ Resource Center at www.pemnet.com