



BULLETIN

- WAVEGARD®
- ELECTROSTATIC
- GROUNDING
- SYSTEM



DR 600

WAVEGARD® GROUNDING SYSTEM

Penn Engineering has developed the WAVEGARD® assembly to provide a practical and cost-effective "earth" ground while allowing easy access to internal components.

The presence of electrical noise can be very detrimental to the operation of electronic devices. Equipment which operates with low-level signals is most affected and requires shielding devices to guard against static discharge and to reduce aperture length and radiation accordingly.

The WAVEGARD® is a two-part system consisting of a spring-loaded plunger assembly and a contact button. The plunger is mounted into a hole in the door frame of the cabinet, and the button is installed in the door directly opposite. When the door is closed, the plunger makes firm contact with the button's surface. These contact points provide a positive conductive path between the cabinet frame and the door.

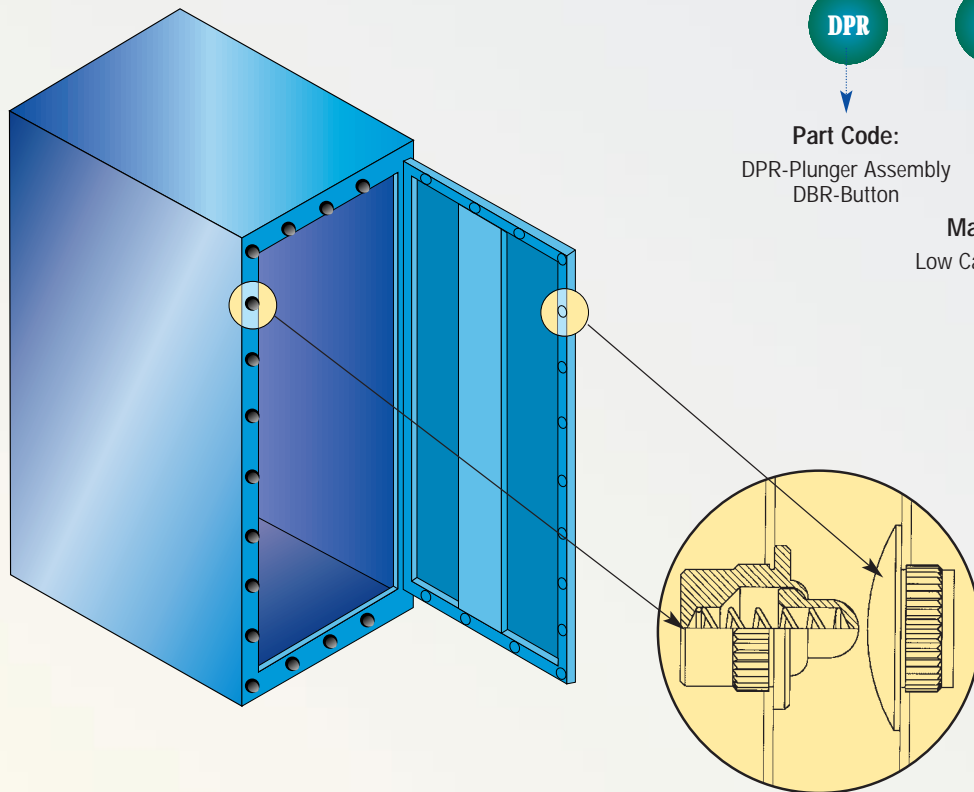

Part Number Designation

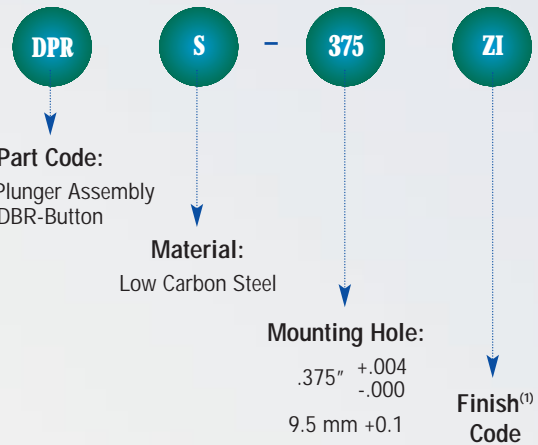

- (1) Finish
- Plunger Assembly:**
- Contact Pin:**
CN - Standard - Bright nickel over copper flash
 - Retainer:**
ZI - Standard - Zinc per ASTM B 633 SC1 (5µm), Type III, Colorless
 - Button:**
CN - Standard - Bright nickel over copper flash

SPECIFICATIONS AND DESIGN DATA

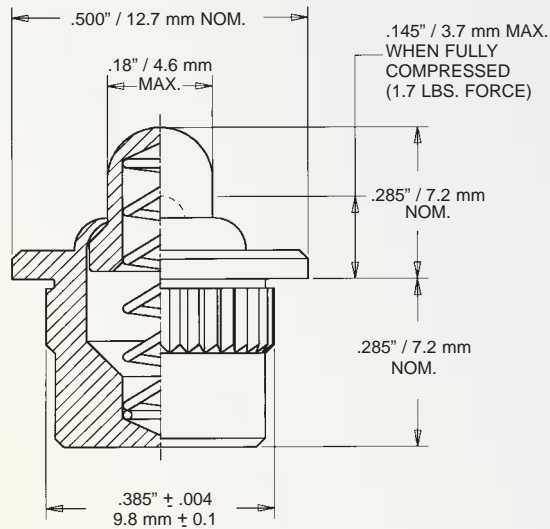

WAVEGARD® PLUNGER

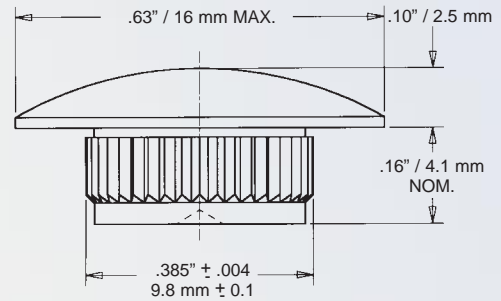

WAVEGARD® BUTTON

INSTALLATION

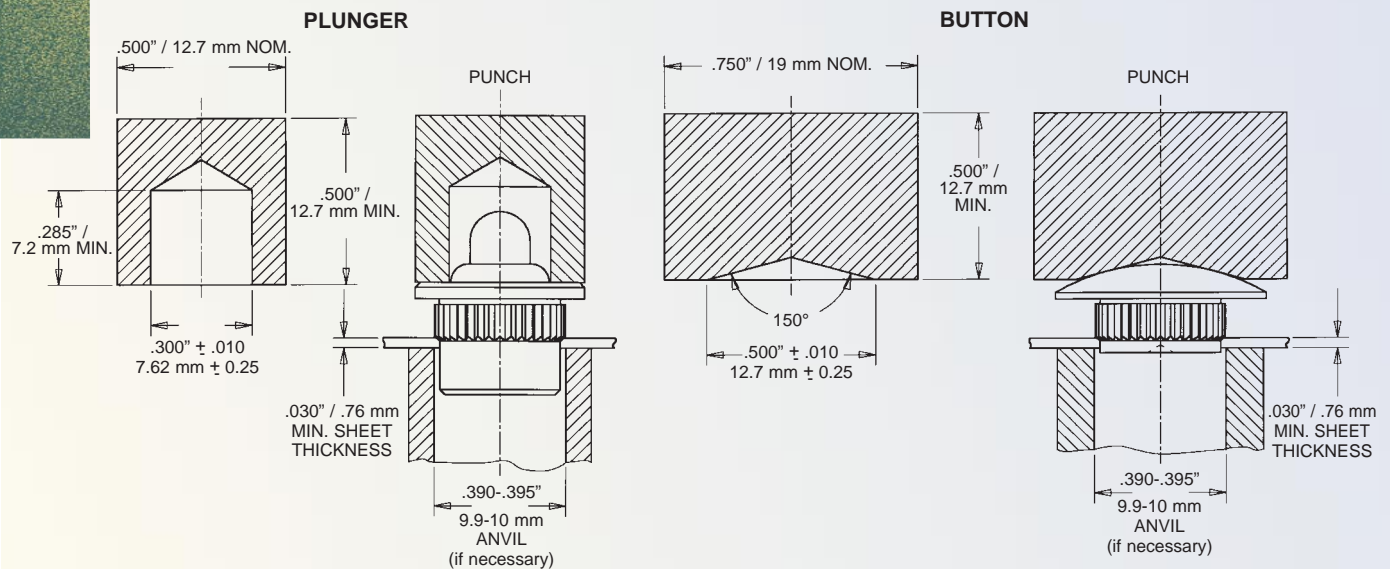

Procedure

1. Punch or drill a $.375\" + .004 - .000 / 9.5 \text{ mm} + 0.1$ mounting hole in sheet. Minimum sheet thickness $.030\" / 0.76 \text{ mm}$.
2. Place shank of plunger or button into mounting hole, preferably the punch side.
3. With punch and anvil surfaces parallel, apply only enough squeezing force until the head comes into contact with the sheet material.

Performance in Cold-Rolled Steel

Installation . . . 1,500 lbs. / 680 kg.
 Pushout650 lbs. / 294 kg.

SHIELDING EFFECTIVENESS TEST METHOD

With the door removed from an enclosure, a field level was established between a transmitting antenna mounted inside the enclosure and a receiving antenna set at the appropriate distance outside the enclosure. The door was then installed on the enclosure with the WAVEGARD® system in place. With the antennas still in the same position and the level unchanged at the transmitting generator the field level was again recorded. The difference between the levels with the enclosure open and then closed is the shielding effectiveness of the enclosure. This procedure was repeated at each of the selected test frequencies.

Values for a typical enclosure with WAVEGARD® devices installed

FREQUENCY MHz	SHIELDING EFFECTIVENESS dB
	SPACING 8" / 20 cm APART
1.0	91
5.0	76
10.0	54
50.0	50
100.0	42
500.0	32
1000.0	20

A graphical representation of these figures appears below.

ELECTROMAGNETIC EMISSION TEST

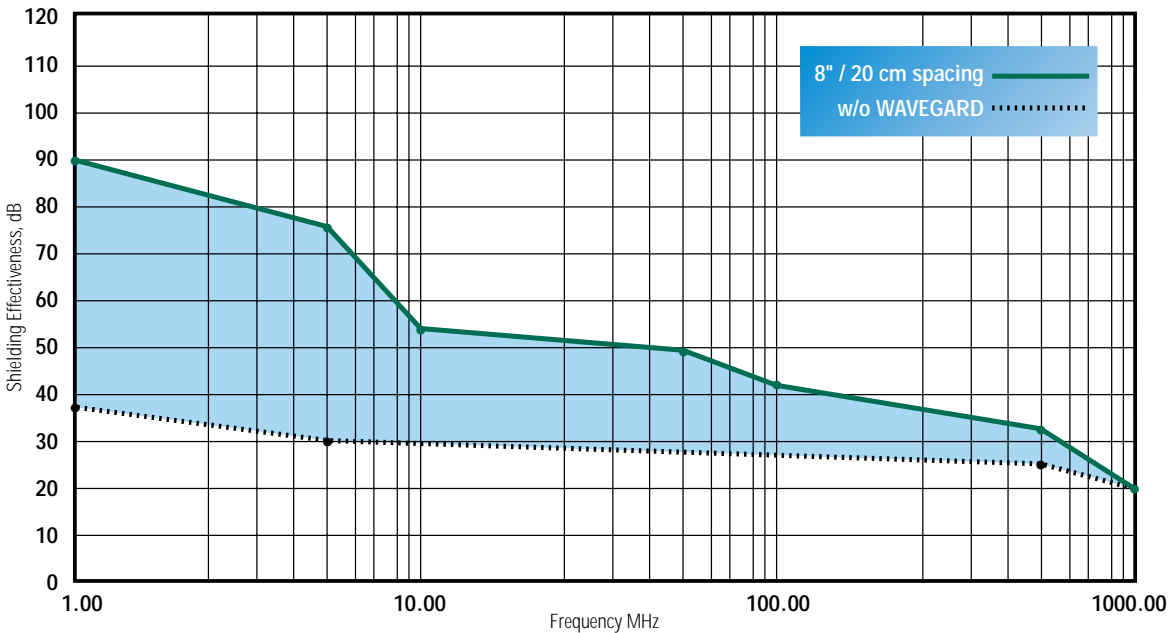

Attenuation measurements were performed using test methods MIL-STD-285.
Test equipment was calibrated in accordance with requirements of MIL-STD-45662.

Specifications subject to change without notice.

Visit us at our PEMNETSM web site:
<http://www.pemnet.com>

For the name of the Authorized PEM distributor nearest you, call one of the numbers below or check our web site.

PEM[®] PENN ENGINEERING & MANUFACTURING CORP.

WORLD HEADQUARTERS:
DANBORO, PENNSYLVANIA 18916 U.S.A.
TEL: 215-766-8853 • FAX: 215-766-3633
SALES: 800-DIAL-PEM (USA Only)
E-MAIL: pem@pemnet.com
WEB SITE: www.pemnet.com

U.K. AND EUROPE:
PEM INTERNATIONAL LTD.
KIRK SANDALL INDUSTRIAL ESTATE
DONCASTER, SOUTH YORKSHIRE
DN3 1QR, ENGLAND
TEL: 01302 886961 • FAX: 01302 885341

ASIA/PACIFIC:
PEM INTERNATIONAL (S) PTE. LTD.
CITIPOINT INDUSTRIAL COMPLEX
152 PAYA LEBAR ROAD #03-06
SINGAPORE 409020
TEL: 65 745 0660 • FAX: 65 745 2400

