

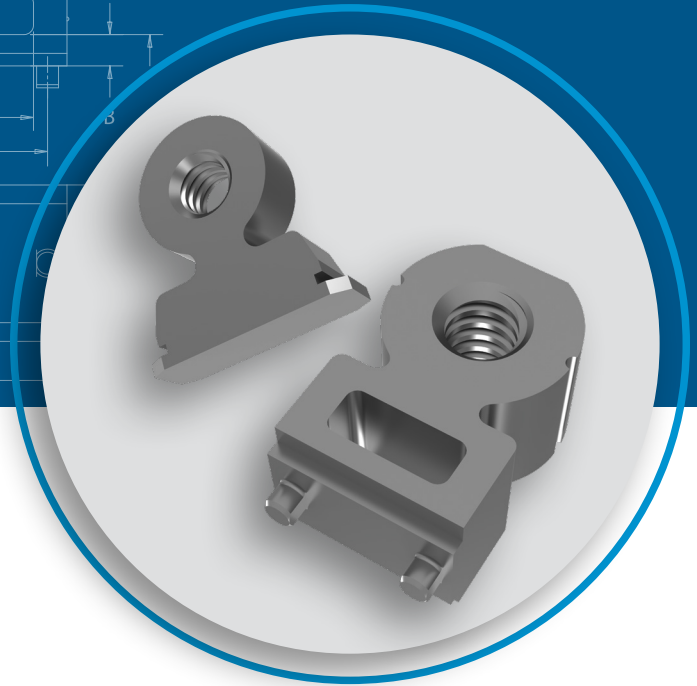

**RA™**

# RIGHT ANGLE FASTENERS

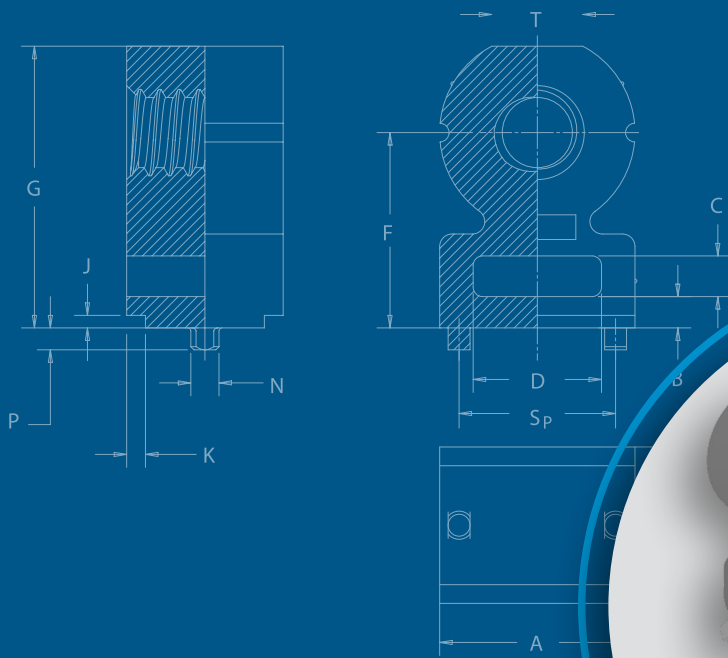

PEM® R'ANGLE® fasteners provide strong right angle attachment points in thin sheets.

PEM® R'ANGLE® fasteners provide strong right angle attachment points in sheet metal or PC Boards. **RAA™** and **RAS™** fasteners for metal are simply pressed into a rectangular mounting hole of the proper size. **SMTRA™** fasteners are installed onto PC Boards using standard surface mount techniques. The holding power of the fastener is unaffected by the repeated tightening and loosening of the screw.

PEM® R'ANGLE® fasteners are cost-effective replacements for:

- Bent edge tabs
- Bent center tabs
- Bent flanges
- Angle brackets
- Tack welds
- Loose hardware

PEM® R'ANGLE® fasteners provide many advantages over bent tabs and flanges, including:

- More predictable designs
- Material savings
- Tighter design control
- Improved shielding characteristics
- Reduction of loose hardware
- Fewer assembly steps
- Unmarred panel surfaces

Fastener drawings and models are available at [www.pemnet.com](http://www.pemnet.com). Custom sizes are available on special order. [Contact us](#) for more information.

**RAS™** fasteners for sheet metal is a threaded right angle fastener that accepts standard unified or metric screws — [PAGE 3](#)



**SMTRA™** right angle threaded fasteners are installed on to PC Boards using standard surface mount techniques. They accept standard unified or metric screws — [PAGE 5](#)

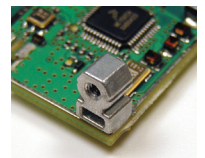

**RAA™** right angle fasteners for sheet metal can accept thread forming or self-tapping screws — [PAGE 4](#)

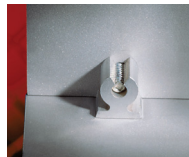

[Material and finish specifications](#) — [PAGE 6](#)

[Installation](#) — [PAGE 6 - 7](#)

[Performance data](#) — [PAGE 7 - 8](#)

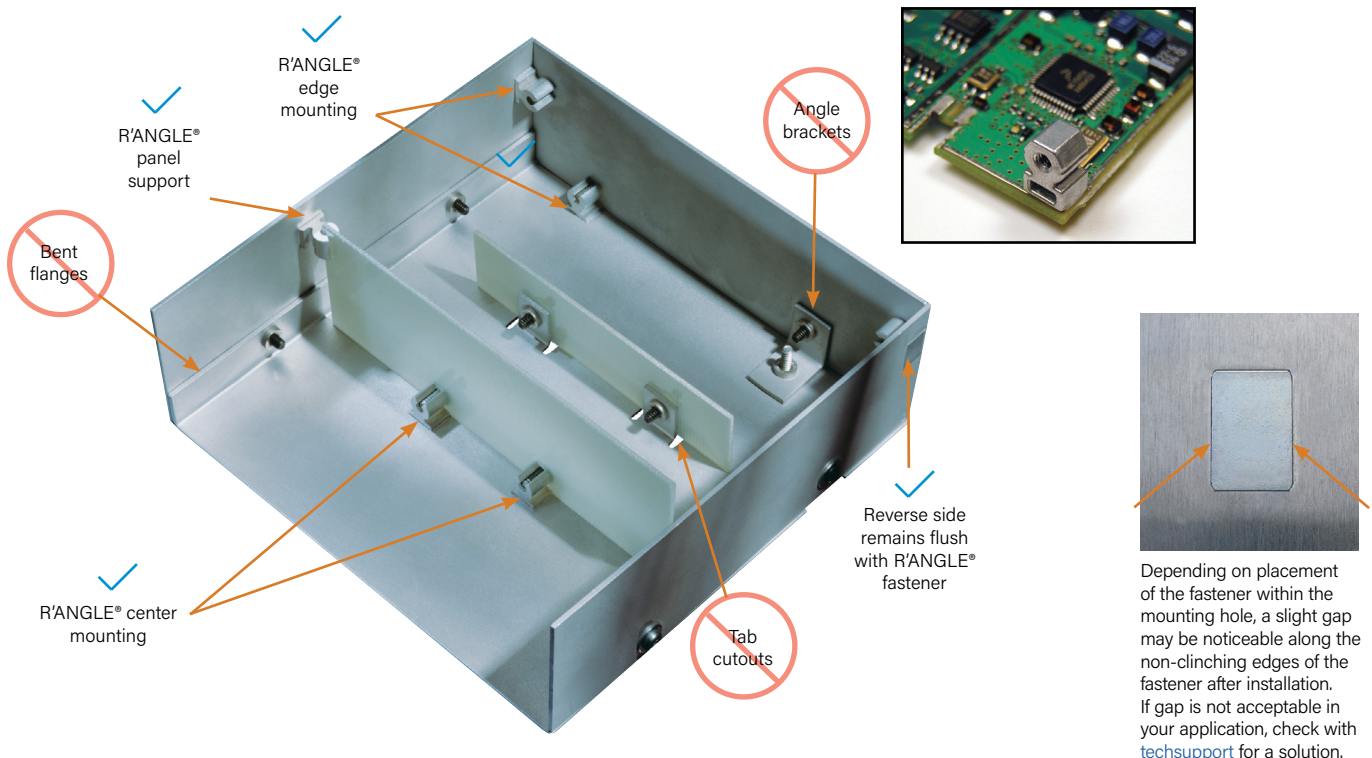

## PEM® RAS™ Threaded Right Angle Fastener

For use with standard metric or unified screws.

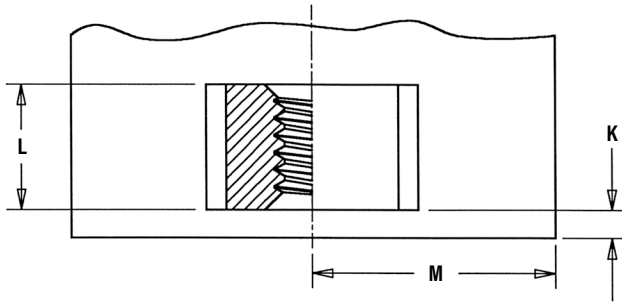

PEM® "Circle on Pedestal"  
(Registered Trademark)

Fastener drawings and models are available at [www.pemnet.com](http://www.pemnet.com)

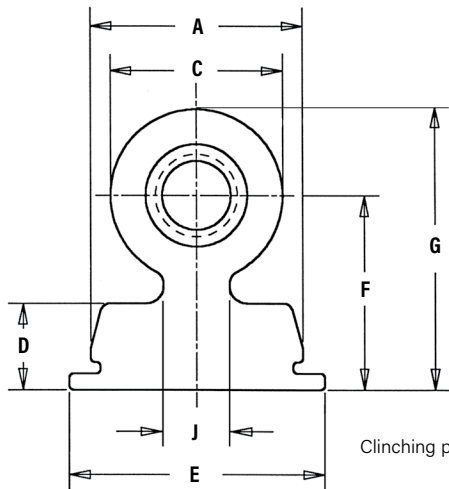
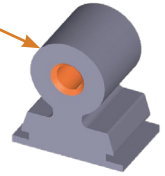

Clinching profile may vary.

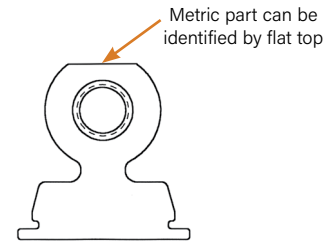

Metric part can be identified by flat top

### Part Number Designation

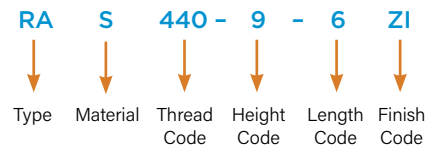

All dimensions are in inches.

Unified	Thread Size	Type	Fastener Material	Thread Code	Height Code	Length Code	Length L ±.003	Min. Sheet Thickness	Hole Size In Sheet +.002 - .001	A ±.003	C Nom.	D Nom.	E ±.006	Height F ±.006	G Nom.	J Nom.	Min. Part Face to Edge K	Min. Dist. Hole C/L to Edge M (1)
	.112-40 (#4-40)	RA	S	440	9	4	.121	.040	.312 x .125	.308	.250	.125	.370	.281	.406	.096	.040	
6						.183	.312 x .187		.35									
8						.246	.312 x .250		.43									
.138-32 (#6-32)	RA	S	632	10	4	.121	.040	.375 x .125	.371	.300	.125	.433	.312	.462	.141	.040		.35
					8	.246		.375 x .250										.50
					10	.308		.375 x .312										.55
.164-32 (#8-32)	RA	S	832	12	6	.183	.040	.406 x .187	.402	.350	.125	.464	.375	.550	.157	.040		.40
					9	.277		.406 x .281										.58
					12	.371		.406 x .375										.65

All dimensions are in millimeters.

Metric	Thread Size x Pitch	Type	Fastener Material	Thread Code	Height Code	Length Code	Length L ±0.08	Min. Sheet Thickness	Hole Size In Sheet +0.05 -0.03	A ±0.08	C Nom.	D Nom.	E ±0.15	Height F ±0.15	G Nom.	J Nom.	Min. Part Face to Edge K	Min. Dist. Hole C/L to Edge M (1)
	M3 x 0.5	RA	S	M3	7	3	2.89	1	8 x 3	7.89	6.35	3.18	9.47	7	9.78	2.87	1.02	
4						3.89	8 x 4		9.1									
6						5.89	8 x 6		10.7									
M4 x 0.7	RA	S	M4	9	4	3.89	1	10 x 4	9.89	8.89	3.18	11.48	9	13.21	4.06	1.02		10
					7	6.89		10 x 7										14.7
					9	8.89		10 x 9										16.3

(1) For more information on proximity to bends and distance to other clinch hardware, see [PEM® Tech Sheet C/L To Edge](#).

## RAA™ Right Angle Fastener

For use with thread forming screws.

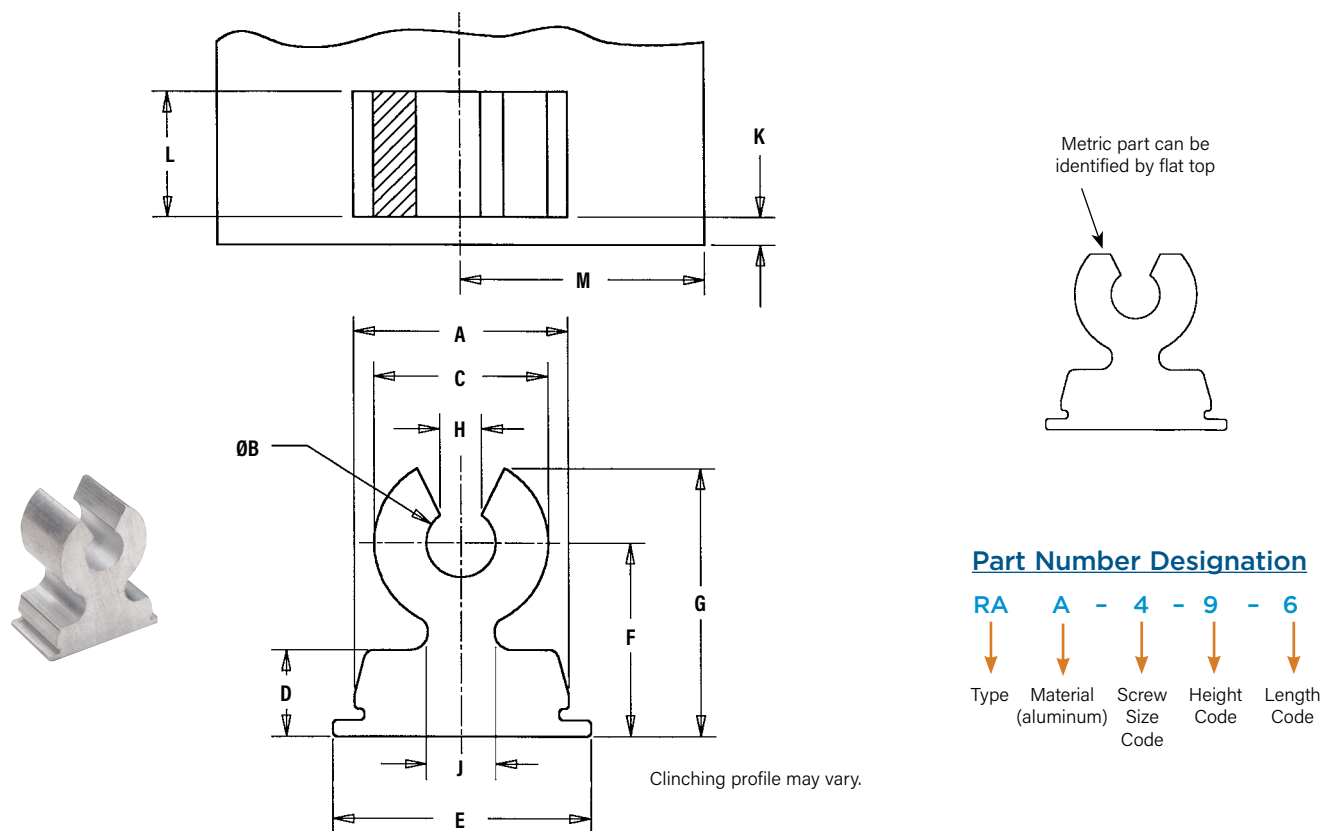

All dimensions are in inches.

Unified	Thread Form Screw Size	Type	Fastener Material	Screw Size Code	Height Code	Length Code	Length L ±.003	Min. Sheet Thickness	Hole Size In Sheet +.002 -.001	A ±.003	ØB ±.004	C Nom.	D Nom.	E ±.006	Height F ±.006	G Nom.	H ±.007	J Nom.	Min. Part Face to Edge K	Min. Dist. Hole C/L to Edge M (1)
	#4-40	RA	A	4	9	6	.183	.040	.312 x .187	.308	.100	.250	.125	.368	.281	.389	.054	.096	.040	.35
8						.246	.312 x .250		.36											
#6-32	RA	A	6	10	8	.246	.040	.375 x .250	.371	.123	.300	.125	.431	.312	.442	.066	.141	.040	.50	
					10	.308		.375 x .312											.55	
#8-32	RA	A	8	12	9	.277	.040	.406 x .281	.402	.145	.350	.125	.462	.375	.525	.078	.157	.040	.58	
					12	.371		.406 x .375											.65	

All dimensions are in millimeters.

Metric	Thread Form Screw Size	Type	Fastener Material	Screw Size Code	Height Code	Length Code	Length L ±0.08	Min. Sheet Thickness	Hole Size In Sheet +0.05 -0.03	A ±0.08	ØB ±0.1	C Nom.	D Nom.	E ±0.15	Height F ±0.15	G Nom.	H ±0.18	J Nom.	Min. Part Face to Edge K	Min. Dist. Hole C/L to Edge M (1)
	M3 x 0.5	RA	A	M3	7	4	3.89	1	8 x 4	7.89	2.77	6.35	3.18	9.42	7	9.27	1.5	2.87	1.02	9.1
6						5.89	8 x 6		10.7											
M4 x 0.7	RA	A	M4	9	7	6.89	1	10 x 7	9.89	3.68	8.89	3.18	11.43	9	12.19	1.97	4.06	1.02	14.7	
					9	8.89		10 x 9											16.3	

(1) For more information on proximity to bends and distance to other clinch hardware, see [PEM® Tech Sheet C/L To Edge](#).

## SMTRA™ Reelfast® Right Angle Fasteners

Surface mounted and threaded to accept standard unified or metric screw.

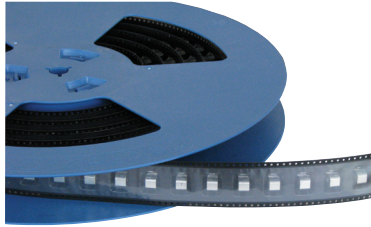

Patented

### Part Number Designation

**SMTRA - 256 - 8 - 6 ET**

Type and Material (zinc die cast)  
 Thread Code  
 Height Code  
 Length Code  
 Finish Code

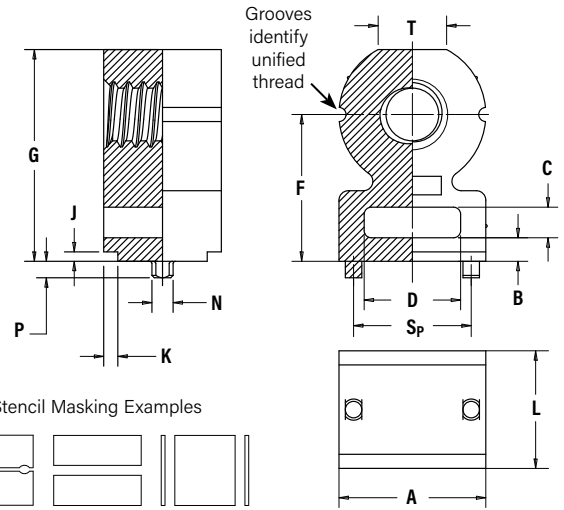

Stencil Masking Examples



All dimensions are in inches.

Unified	Thread Size	Type	Thread Code	Height Code	Length Code	Length L ±.005	Min. Sheet Thickness	Hole Size In Sheet +.003 -.000	A ±.006	B ±.006	C ±.006	D ±.006	Height F ±.006	G ±.006	J Nom.	K Nom.	N Max.	P Max.	Sp ±.003	T Nom.
	.086-56 (#2-56)	SMTRA	256	8	6	.188	.040	.053	.218	.040	.060	.140	.250	.345	.020	.030	.048	.040	.157	.105
.112-40 (#4-40)	SMTRA	440	9	6	.188	.040	.053	.250	.050	.065	.160	.281	.390	.020	.030	.048	.040	.188	.125	
.138-32 (#6-32)	SMTRA	632	10	8	.250	.040	.053	.312	.050	.065	.205	.312	.450	.020	.030	.048	.040	.250	.145	
.164-32 (#8-32)	SMTRA	832	12	9	.281	.040	.053	.375	.050	.075	.250	.375	.535	.020	.030	.048	.040	.312	.195	

All dimensions are in millimeters.

Metric	Thread Size x Pitch	Type	Thread Code	Height Code	Length Code	Length L ±0.13	Min. Sheet Thickness	Hole Size In Sheet +0.08	A ±0.15	B ±0.15	C ±0.15	D ±0.15	Height F ±0.15	G ±0.15	J Nom.	K Nom.	N Max.	P Max.	Sp ±0.08	T Nom.
	M2 x 0.4	SMTRA	M2	6	5	5	1	1.35	5.5	1	1.5	3.5	6	8.4	0.5	0.75	1.22	1	4	2.65
M2.5 x 0.45	SMTRA	M25	6	5	5	1	1.35	5.5	1	1.5	3.5	6	8.4	0.5	0.75	1.22	1	4	2.65	
M3 x 0.5	SMTRA	M3	7	5	5	1	1.35	6.35	1.25	1.65	4	7	9.75	0.5	0.75	1.22	1	4.75	3.2	
M4 x 0.7	SMTRA	M4	9	7	7	1	1.35	9.53	1.25	1.65	6.35	9	13.1	0.5	0.75	1.22	1	7.9	4.8	

Unified	Thread Code	Pad Width PA Min.	Pad Length PL Min.	Hole Spacing SH ±.002	Hole Size In Sheet +.003 -.000
	256	.262	.171	.157	.053
440	.294	.171	.188	.053	
632	.356	.233	.250	.053	
832	.419	.264	.312	.053	

Metric	Thread Code	Pad Width PA Min.	Pad Length PL Min.	Hole Spacing SH ±0.05	Hole Size In Sheet +0.08
	M2	6.62	4.57	4	1.35
M25	6.62	4.57	4	1.35	
M3	7.47	4.57	4.75	1.35	
M4	10.65	6.57	7.9	1.35	

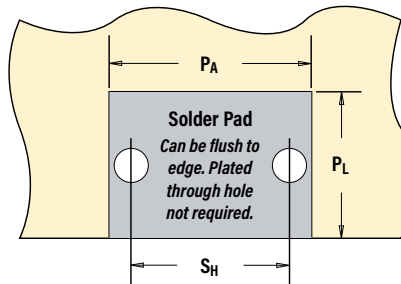

If desired, space can be used for fast cable tie mounting.

Part Number	Parts Per Reel	Pitch (mm)	Tape Width (mm)
SMTRA256-8-6	375	16	24
SMTRA440-9-6	300	16	24
SMTRA632-10-8	200	20	32
SMTRA832-12-9	200	20	32
SMTRAM2-6-5	375	16	24
SMTRAM25-6-5	375	16	24
SMTRAM3-7-5	300	16	24
SMTRAM4-9-7	200	20	32

## Material And Finish Specifications

Type	Threads	Fastener Materials			Standard Finishes <sup>(1)</sup>			For Use In Sheet Hardness: <sup>(2)</sup>			
	Internal, ASME B1.1, 2B ASME B1.13M, 6H	Aluminum	Steel	Zinc Die Cast	Zinc Plated per ASTM B633, SC1 (5µm), Type III, Colorless	Natural	Electro-plated Tin ASTM B 545, Class A with Clear Preservative Coating, Annealed	HRB 45 / HB 84 or Less	HRB 60 / HB 107 or Less	PC Board	
RAS	▪		▪		▪				▪		
RAA		▪				▪		▪			
SMTRA	▪			▪			▪			▪	
Part Number Codes for Finishes					ZI	None	ET <sup>(3)</sup>				

- (1) See PEM® Technical Support section of our website for related plating standards and specifications.
- (2) HRB - Hardness Rockwell "B" Scale, HB - Hardness Brinell.
- (3) Optimal solderability life noted on packaging.

Custom sizes are available on special order. [Contact us](#) for more information.

## Installation

### RAS™ and RAA™ Fasteners

1. Prepare a properly sized rectangular mounting hole in the sheet. Do not perform any secondary operations such as deburring.
2. Place the fastener through the mounting hole (preferably the punch side) and into the anvil as shown in the drawing to the right.
3. With the installation punch and anvil surfaces parallel, apply a squeezing force until the bottom of the fastener becomes flush with the sheet.

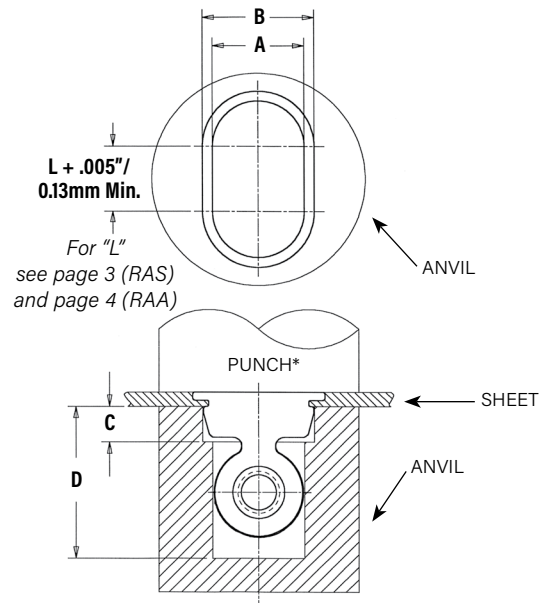

### Installation Tooling

Unified	Screw Thread Size Code	HAEGER® Part No.		PEMSERTER® Part No.		Anvil Dimensions (in.)			
		Anvil	Punch	Anvil	Punch	A ±.001	B ±.001	C ±.005	D Min.
	4/440	H-180-440-L	H-108-0020L	8002711	8003076	.257	.313	.100	.425
6/632	H-180-632-L	H-108-0020L	8002712	8003076	.307	.376	.100	.500	
8/832	H-180-832-L	H-108-0020L	8003642	8003076	.357	.407	.100	.575	

Metric	Screw Thread Size Code	HAEGER® Part No.		PEMSERTER® Part No.		Anvil Dimensions (mm)			
		Anvil	Punch	Anvil	Punch	A ±0.03	B ±0.03	C ±0.1	D Min.
	M3	H-180-M3-L	H-108-0020L	8002713	8003076	6.53	8.02	2.54	10.8
M4	H-180-M4-L	H-108-0020L	8002714	8003076	9.07	10.03	2.54	12.7	

\* NOTE: The punch must be large enough to cover the entire base of the fastener to ensure proper installation.

Installation tooling is available from PennEngineering.

### Mounting Hole Examples

The mounting hole is defined by two dimensions. The two thick lines shown must be straight for the entire length defined by "Side 2" and must be separated by the distance shown as "Side 1" (Side 1 and Side 2 are the two dimensions given for the mounting hole on pages 3 and 4). The illustration shows three examples (#1, #2, and #3) of how it can be achieved. Example #4 in the lower right side will not work.

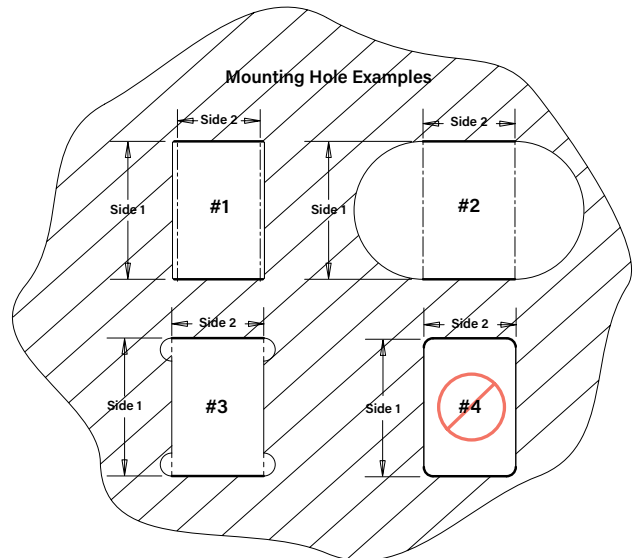

### Installation Notes

- For best results we recommend using a HAEGER® or PEMSERTER® machine for installation of PEM® self-clinching fasteners. Please check our website for more information.
- Visit the Animation Library on our website to view the installation process [for this product](#).



## SMTRA™ Surface Mount Fasteners

Flat top for vacuum pick up.

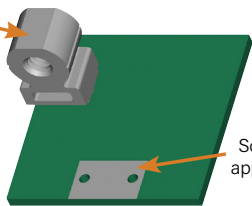

Solder paste applied to pad on PCB.

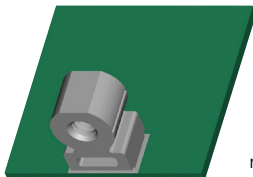

Solder fastener in place using standard surface mount techniques.

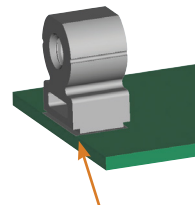

Undercut to accept solder fillet and permit flush to edge installation.

## For Additional HAEGER® and PEMSERTER® Tooling Information / Part Numbers



HAEGER® MANUAL TOOLING CATALOG

HAEGER® AUTO TOOLING CATALOG

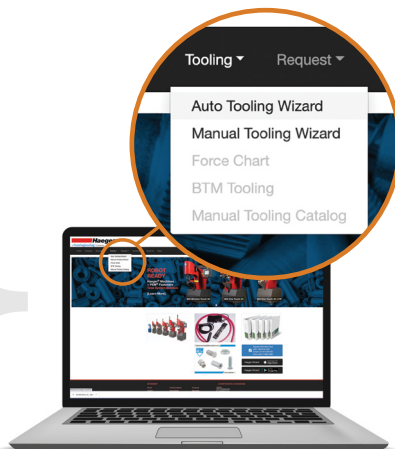

Go to [haeger.com](http://haeger.com) to access the Auto and Manual Tooling Wizards

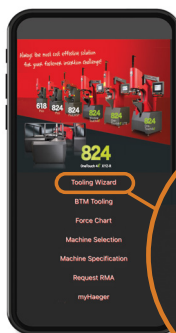

Or download the HAEGER WIZZARD Phone App

OneTouch 4e XYZ-R  
Tooling Wizard  
BTM Tooling



PEMSERTER® MANUAL TOOLING CATALOG

PEMSERTER® AUTO TOOLING CATALOG

## SMTRA™ R'ANGLE® Fasteners With ET Finish<sup>(1)(2)</sup>

Unified	Part Number	Pullout (lbs.)	Side Load (lbs.)
	SMTRA256-8-6	51.7	7.1
	SMTRA440-9-6	89.5	10.8
	SMTRA632-10-8	110.3	8.4
	SMTRA832-12-9	137.2	21.2

Metric	Part Number	Pullout (N)	Side Load (N)
	SMTRAM2-6-5	418.2	56.8
	SMTRAM25-6-5	216.5	36.9
	SMTRAM3-7-5	257.6	41.3
	SMTRAM4-9-7	369.3	73.3

### Testing Conditions

Oven	Quad ZCR convection oven with 4 zones
Vias	None
High Temp	518°F / 270°C
Board Finish	62% Sn, 38% Pb
Paste	Amtech NC559LF Sn96.5/3.0Ag/0.5Cu (SAC305) Lead-free
Board	.062" thick, Single Layer FR-4
Stencil	.0067" / 0.17 mm thick
Screen Printer	Ragin Manual Printer

- (1) With lead-free paste. Average values of 30 test points. The data presented here is for general comparison purposes only. Actual performance is dependent upon application variables. We will be happy to provide samples for you to install. If required, we can also test your installed hardware and provide you with the performance data specific to your application.
- (2) Further testing details can be found in the literature section on our website.

## Performance Data<sup>(1)</sup>

### RAS™ Threaded Fasteners

Unified	Thread Code	Height Code	Length Code	Test Sheet Material									
				5052-H34 Aluminum					Cold-rolled Steel				
				Max. Rec. Tightening Torque (in. lbs.)	Installation (lbs.)	Pushout (lbs.) (2)	Side Load (lbs.) (3)	Pull Thru (lbs.)	Max. Rec. Tightening Torque (in. lbs.)	Installation (lbs.)	Pushout (lbs.) (2)	Side Load (lbs.) (3)	Pull Thru (lbs.)
440	9	4	13	1800	100	7	80	16	2400	180	9	80	
		6	17	1800	145	8	80	17	2400	260	9	80	
		8	17	2100	180	13	80	17	3000	315	15	80	
632	10	4	20	2000	100	7	85	20	2500	190	9	85	
		8	21	2500	190	12	85	26	3200	335	16	85	
		10	21	2800	230	16	85	26	4000	385	20	85	
832	12	6	20	2400	140	15	100	27	3200	260	11	100	
		9	23	3300	195	16	100	29	4200	345	20	100	
		12	30	3500	260	20	100	35	4700	420	27	100	

Metric	Thread Code	Height Code	Length Code	Test Sheet Material									
				5052-H34 Aluminum					Cold-rolled Steel				
				Max. Rec. Tightening Torque (N-m)	Installation (kN)	Pushout (N) (2)	Side Load (N) (3)	Pull Thru (N)	Max. Rec. Tightening Torque (N-m)	Installation (kN)	Pushout (N) (2)	Side Load (N) (3)	Pull Thru (N)
M3	7	3	1.47	8	423	36	356	2.26	10.7	778	40	356	
		4	1.92	8	534	36	356	2.71	10.7	1001	40	356	
		6	2.15	9.3	756	58	356	2.71	13.3	1312	67	356	
M4	9	4	2.15	8.9	556	53	423	3.28	11.6	956	44	423	
		7	2.6	13.3	890	76	423	4.07	16	1512	80	423	
		9	2.83	13.3	1112	93	423	4.52	18.7	1846	116	423	

### RAA™ Fasteners

Unified	Screw Size Code	Height Code	Length Code	Thread Forming Torque (in. lbs.)	Max. Rec. Tightening Torque (in. lbs.)	Test Sheet Material	Installation (lbs.)	Pushout (lbs.) (2)	Side Load (lbs.) (3)	Pull Thru (lbs.)										
											4	9	6	3	6	5052-H34 Aluminum	1800	140	8	80
													8	4	10		1800	180	13	80
6	10	8	5.5	11	5052-H34 Aluminum	2500	175	12	85											
		10	5.5	17		2500	235	16	85											
8	12	9	6.5	18	5052-H34 Aluminum	3100	205	13	105											
		12	8.0	20		3100	255	21	105											

Metric	Screw Size Code	Height Code	Length Code	Thread Forming Torque (N-m)	Max. Rec. Tightening Torque (N-m)	Test Sheet Material	Installation (kN)	Pushout (N) (2)	Side Load (N) (3)	Pull Thru (N)										
											M3	7	4	.17	.56	5052-H34 Aluminum	71	556	27	356
													6	.23	1.02		71	756	44	356
M4	9	7	.56	2.26	5052-H34 Aluminum	13.3	890	76	423											
		9	.56	2.83		13.3	1045	107	423											

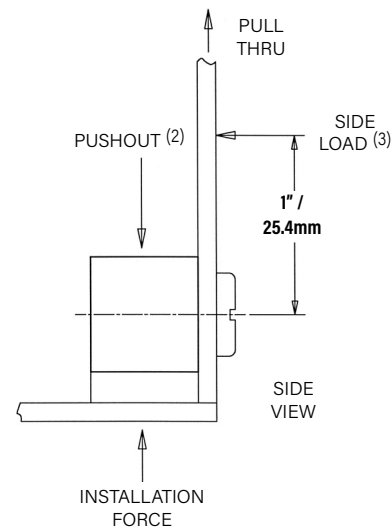

- (1) Published installation forces are for general reference. Actual set-up and confirmation of complete installation should be made by observing proper seating of fastener as described in the installation steps. Other performance values reported are averages when all proper installation parameters and procedures are followed. Variations in mounting hole size, sheet material, and installation procedure may affect performance. Performance testing this product in your application is recommended. We will be happy to provide technical assistance and/or samples for this purpose.
- (2) Pushout test is conducted without side panel attached to R'ANGLE® fastener.
- (3) 1" / 25.4mm from screw centerline.

All PEM® products meet our stringent quality standards. If you require additional industry or other specific [quality certifications](#), special procedures and/or part numbers are required. Please contact your local sales office or representative for further information.

Regulatory [compliance information](#) is available in Technical Support section of our website. Specifications subject to change without notice. See our website for the most current version of this bulletin.



**North America:** Danboro, Pennsylvania USA | E-mail: [info@pemnet.com](mailto:info@pemnet.com) | Tel: +1-215-766-8853 | 800-237-4736 (USA)  
**Europe:** Galway, Ireland | E-mail: [europa@pemnet.com](mailto:europa@pemnet.com) | Tel: +353-91-751714  
**Asia/Pacific:** Singapore | E-mail: [singapore@pemnet.com](mailto:singapore@pemnet.com) | Tel: +65-6-745-0660  
**Shanghai, China:** E-mail: [china@pemnet.com](mailto:china@pemnet.com) | Tel: +86-21-5868-3688

Visit our PEMNET™ Resource Center at [www.pemnet.com](http://www.pemnet.com) • Technical support e-mail: [techsupport@pemnet.com](mailto:techsupport@pemnet.com)