



# AUTOMOTIVE ELECTRONICS FASTENING DESIGN STANDARDS



DISCOVER THE DIFFERENCE

## Table of Contents

Click links below for shortcuts to information.

---

- [PEM® / SI® Innovation](#)
  - [Automotive Electronics Applications:](#)
    - [Powertrain](#)
    - [Infotainment](#)
    - [Safety & ADAS](#)
    - [Body Electronics](#)
  - [PEM® Fasteners](#)
  - [SI® Fasteners](#)
- 

## SEE HOW THE INNOVATIVE THINKING BEHIND OUR FASTENING SOLUTIONS CAN MOVE YOU FORWARD

From airbags to infotainment systems, the PennEngineering® family of fastener solutions – including PEM® and SI® brands – can be found in practically any automotive electronics system. In fact, over 90% of automakers rely on our forward-thinking innovation.

With new capabilities and one of the largest and most diverse portfolios in the industry, see how you can move forward with greater cost savings, reliability, and eco-friendly performance.

## DESIGN ENGINEERED FOR ALL OF YOUR CRITICAL AUTOMOTIVE ELECTRONICS APPLICATIONS

The complexity and use of electronics-based vehicle systems grows every day. They're a critical piece of automotive architecture – keeping navigation systems running, lights powered, batteries charged.

PEM® self clinching fasteners and SI® threaded inserts for plastics play a critical role in the performance of those systems. Whether it's a standard catalog fastener, custom part, or total system solution, our engineering expertise makes it possible to design a solution for any application.



Safety & ADAS



Powertrain



Body Electronics



Infotainment

## Table of Contents

Click links below for shortcuts to information.

- [PEM® / SI® Innovation](#)
- [Automotive Electronics Applications:](#)
  - [Powertrain](#)
  - [Infotainment](#)
  - [Safety & ADAS](#)
  - [Body Electronics](#)
- [PEM® Fasteners](#)
- [SI® Fasteners](#)

# 90%

## OF TODAY'S TOP AUTOMAKERS RELY ON PEM® SELF CLINCHING FASTENING SOLUTIONS.

### DISCOVER THE DIFFERENCE WITH PEM® SELF CLINCHING FASTENERS

Using PEM® self clinching fastening solutions doesn't just help you achieve better performance. With the benefits below, you'll also comply with industry standards and achieve lead time reduction – a winning combination that gives you a competitive edge.

#### One Single Part Number, Anywhere in the World

We offer one single part number for each of our standard parts, making it easy for you to order while increasing product availability.

#### PPAP Available Parts, Off the Shelf

Our extensive portfolio of standard parts is PPAP ready, directly off the shelf, to help you reduce your critical lead times.

#### Choose Your Technical Cleanliness Level

With our PEM® Clean Lab, you can achieve C400 and C600 technical cleanliness in accordance with your project specifications.

#### Total System Solution with Haeger® Installation Machines

Get even greater efficiency and reliability when you use PEM® fasteners with Haeger® installation machines – a total system solution.

## WHY CHOOSE PEM® SELF CLINCHING FASTENERS

PennEngineering® was founded on a single revolutionary product - an easy-to-install, self clinching fastener that provides load-carrying threads in metal sheets too thin to be tapped.

Today, PEM® fasteners include hundreds of innovative products that provide hundreds of design applications - with unmatched quality, performance, and reliability.

## FEWER PARTS. FEWER ASSEMBLY STEPS. FASTER TIME TO MARKET

PEM® fasteners attach to a sheet of ductile material by causing the material to cold-flow under pressure into an annular recess of the fastener - securely locking it into place:

**Strength** - Stronger threads vs. a tapped panel

**In-Process Installation** - Parts are installed into a plain round hole with no secondary operations required

**Cost Reduction** - Decreased installation cycle times with in-die capability

**Design Flexibility** - Can be installed into dissimilar metals

**Clean Process** - Environmentally friendly, with no weld splatter and less energy requirements

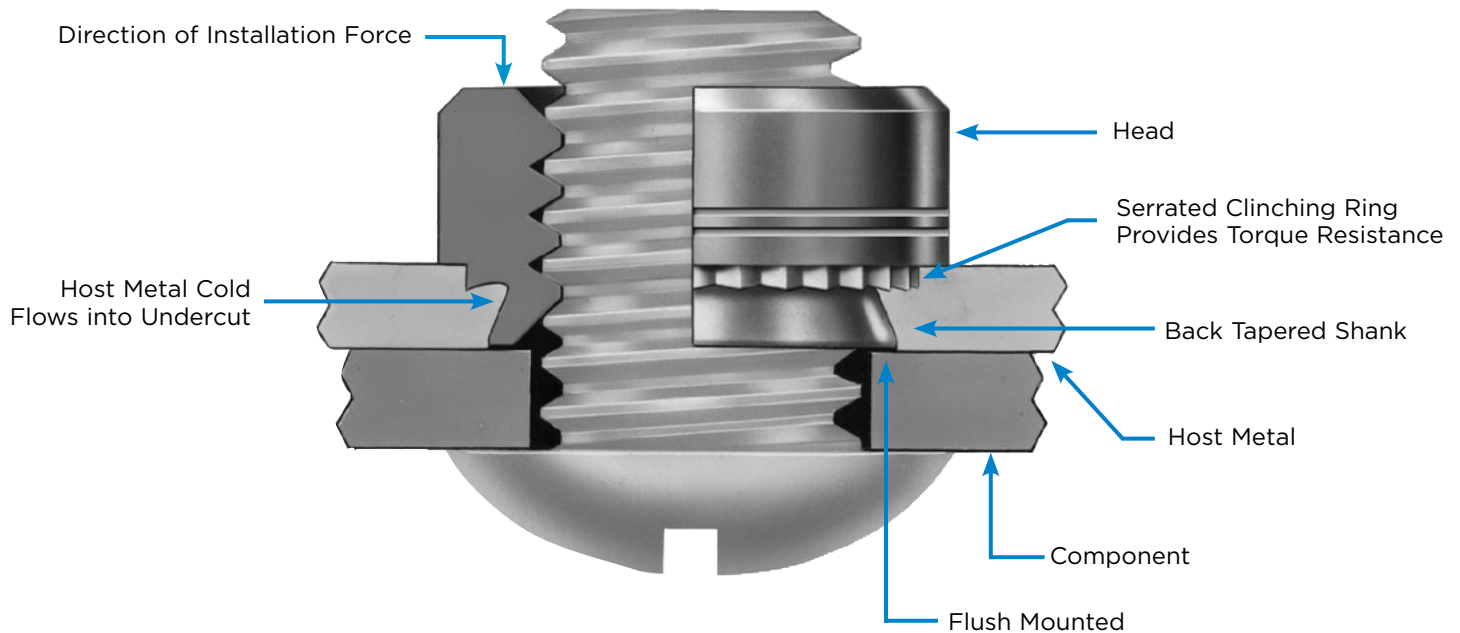

## Table of Contents

Click links below for shortcuts to information.

- [PEM® / SI® Innovation](#)
- [Automotive Electronics Applications:](#)
  - [Powertrain](#)
  - [Infotainment](#)
  - [Safety & ADAS](#)
  - [Body Electronics](#)
- [PEM® Fasteners](#)
- [SI® Fasteners](#)

## TECHNICAL CLEANLINESS STARTS WITH PEM® CLEAN LAB

As automotive electronics components get more compact, even the smallest particle contamination puts performance at risk. To ensure the technical cleanliness of PEM® fasteners, our PEM® Clean Lab uses the most sophisticated cleaning and testing processes to meet today's clean requirements.

Our Clean Lab can test for technical cleanliness in accordance with customer specifications and ISO 16232 and VDA 19 standards, and all parts presented in this catalog meet technical cleanliness guidelines.



## SI® THREADED INSERTS FOR PLASTIC

As automakers convert more assemblies from metal to plastic, SI® inserts have been specified to provide strong, reusable, wear-resistant threads especially when frequent assembly and disassembly is required.

### Sample Applications

Control Modules  
Current-Carrying Devices  
Busbar  
Powertrain  
Thermal Management  
Housings – Cameras, Taillights  
Electric Vehicles

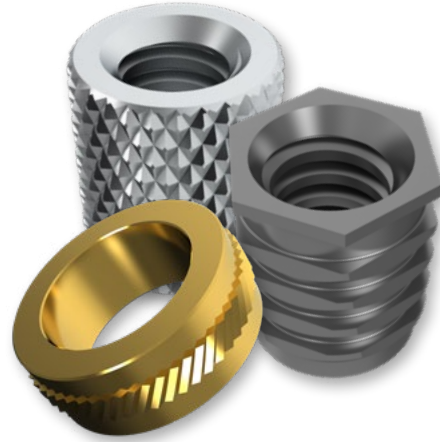

## SI® COMPRESSION LIMITERS

SI® Compression Limiters are non-threaded inserts for applications where compressive load is applied to a plastic assembly – strengthening the plastic and withstanding the compressive force applied during assembly.

- Plastic integrity uncompromised by applied load
- Custom-engineered for many sizes and profiles
- Flexible materials – brass, stainless steel, lead-free aluminum
- Press-in, mold-in, heat staking, ultrasonic installation
- Design types – flange head, symmetrical, full diamond knurl, non-knurled symmetrical

[FOR A QUOTE, TRY THE NEW SI® COMPRESSION LIMITER CONFIGURATION TOOL](#)

## GET A TOTAL SYSTEM SOLUTION WITH PEM® FASTENERS AND HAEGER® INSTALLATION MACHINES

Whether you're new to hardware insertion or insert millions of fasteners per year, using PEM® parts with Haeger® installation machines provides a total system solution – engineered to work together for greater efficiency, reliability, and cost savings.



[WATCH INSTALLATION VIDEO](#)

## Table of Contents

Click links below for shortcuts to information.

- [PEM® / SI® Innovation](#)
- [Automotive Electronics Applications:](#)
  - [Powertrain](#)
  - [Infotainment](#)
  - [Safety & ADAS](#)
  - [Body Electronics](#)
- [PEM® Fasteners](#)
- [SI® Fasteners](#)

## SEE WHAT'S POSSIBLE WITH PEM® SELF CLINCHING

### POWERTRAIN

From electronics systems for engine control or fuel supply, to busbars and connectors that carry critical power, our solutions ensure top performance for many applications.

#### Sample Applications

Battery Management Systems  
Battery Connections  
Busbars  
Motors

#### PEM® Solutions

[Self Clinching Nuts](#)  
[Self Clinching Studs](#)  
[Micro Standoff](#)  
[High Voltage Busbar Studs](#)  
[Captive Spinning Flare Nut](#)  
[SI Molded Insert](#)

### SAFETY & ADAS

Our fastening solutions provide peace of mind for vehicle safety and ADAS applications and are used in systems for electronic power steering, ABS, object detection, and more.

#### Sample Applications

Multi-Camera Systems  
Radar and Lidar  
Electronic Power Steering  
Smart Mirrors

#### PEM® Solutions

[microPEM® TackSert® Fastener](#)  
[Self Clinching Studs](#)  
[Self Clinching Nuts](#)  
[PCB Surface Mount Standoffs](#)  
[SI Molded Insert](#)

### BODY ELECTRONICS

From window and door control to on-board diagnostics systems, our solutions are used in many body electronics applications that deliver driver comfort and convenience.

#### Sample Applications

ECU  
Lighting Systems  
Window Control  
HVAC

#### PEM® Solutions

[Self Clinching Studs](#)  
[Spinning Flare Nuts](#)  
[microPEM® TackPin® Fastener](#)  
[Cable Tie-mount Fasteners](#)  
[SI Molded Insert](#)

# FASTENING SOLUTIONS

## **INFOTAINMENT**

Our fastening solutions are used in many infotainment applications, providing reliability to connectivity and telematics systems, dashboard instrumentation, audio/video, and more.

### **Sample Applications**

Display Units  
Navigation Units  
Heads-Up Display  
Rear Passenger Entertainment

### **PEM® Solutions**

[Self Clinching Nuts](#)  
[Self Clinching Pins](#)  
[Self Clinching Standoffs](#)  
[PCB Surface Mount Standoffs](#)

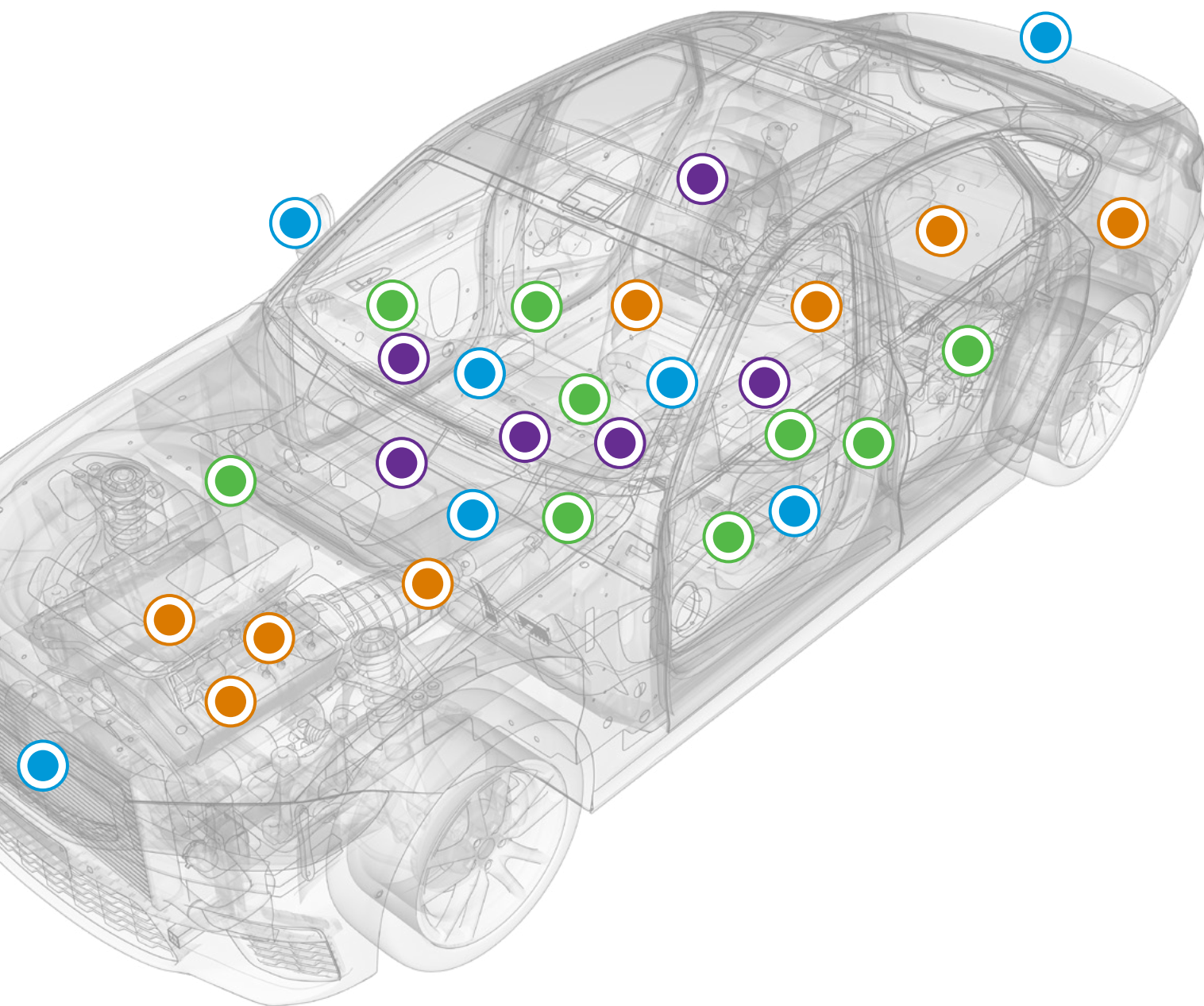

## Table of Contents

Click links below for shortcuts to information.

- [PEM® / SI® Innovation](#)
- [Automotive Electronics Applications:](#)
  - [Powertrain](#)
  - [Infotainment](#)
  - [Safety & ADAS](#)
  - [Body Electronics](#)
- [PEM® Fasteners](#)
- [SI® Fasteners](#)

## EXPERTISE TO TAKE YOU FURTHER

Our fastening solutions are not just precisely designed and manufactured. They're also backed by expert technical support services – so you can always be confident in our product quality and reliability.

- Application Engineering Support
- Technical Lab Services & Testing
- Prototype Development Center
- Installation Equipment Solutions
- Global Distribution Network

### NEED INFORMATION ON A SPECIFIC PRODUCT? BROWSE OUR AUTOMOTIVE ELECTRONICS FASTENING DESIGN STANDARDS

To see our full range of self clinching fastening solutions, visit [PEMnet.com](http://PEMnet.com). To learn about our in-die fastener installation solutions, [click here](#).

For assistance with technical information or to request samples, call **800-342-5736** or email us at [info@pemnet.com](mailto:info@pemnet.com).

# AUTOMOTIVE ELECTRONICS FASTENING DESIGN STANDARDS

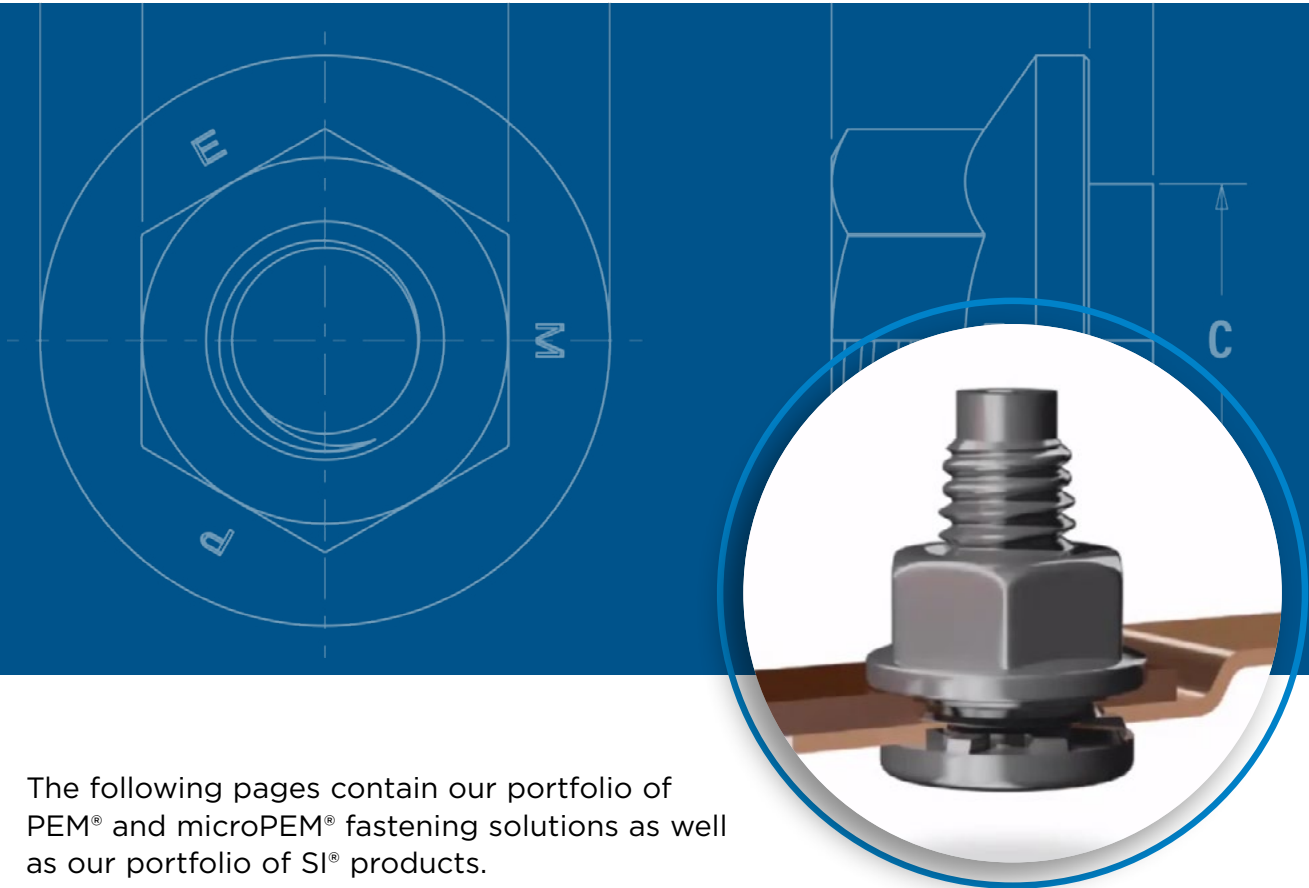

The following pages contain our portfolio of PEM® and microPEM® fastening solutions as well as our portfolio of SI® products.

## Table of Contents

Click links below for shortcuts to information.

- [PEM® / SI® Innovation](#)
- [Automotive Electronics Applications:](#)
  - [Powertrain](#)
  - [Infotainment](#)
  - [Safety & ADAS](#)
  - [Body Electronics](#)
- [PEM® Fasteners:](#)
  - [AUB™ Nut](#)
  - [AUS™ Nut](#)
  - [AUFH™ Studs](#)
  - [AUHFH™ Studs](#)
  - [AUHFE™ Studs](#)
  - [AUTHFE™ Studs](#)
  - [AUSO™ Standoff](#)
  - [AUBSO™ Standoff](#)
  - [AUSMT™](#)
  - [AUKF2™](#)
  - [AUKFE™](#)
  - [AUKFB3™](#)
  - [AUSFN™](#)
- [SI® Fasteners](#)
  - [Flanged Head Compression Limiters](#)
  - [Symmetrical Compression Limiters](#)
  - [Full Diamond Knurl Compression Limiters](#)
  - [Non-Knurled Symmetrical Compression Limiters](#)
  - [Ultrasonic/Heat Staking Inserts](#)
  - [Blind Threaded Molded-in Inserts](#)
  - [Thru-threaded, Knurled Molded-in Inserts](#)
  - [Hexagonal Press-in Inserts](#)

## PEM® FASTENERS

The innovation behind PEM® fastening solutions can add significant value and cost savings to your most complex automotive electronics requirements. Our portfolio is one of the largest and most diverse in the industry.



[AUB™ Nut  
Self Clinching Blind  
Fasteners](#)

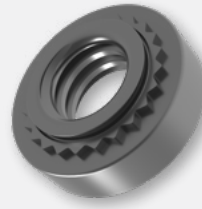

[AUS™ Nut  
CL Self Clinching  
Fasteners](#)



[AUFH™ Studs  
Self Clinching Studs  
and Pins](#)



[AUHFH™ Studs  
Self Clinching Studs  
and Pins](#)



[AUHFE™ Studs  
Self Clinching  
Studs and Pins](#)



[AUTHFE™ Studs  
Self Clinching Studs  
and Pins](#)

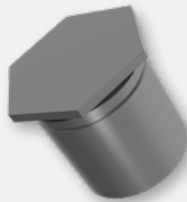

[AUBSO™ Standoff  
Self Clinching  
Blind Standoffs](#)



[AUSO™ Standoff  
Self Clinching  
Standoffs](#)



[AUSMT™  
Fasteners for use  
with PC Boards](#)



[AUKF2™  
Fasteners for use  
with PC Boards](#)



[AUKFE™  
Fasteners for use  
with PC Boards](#)



[AUKFB3™  
Fasteners for use  
with PC Boards](#)

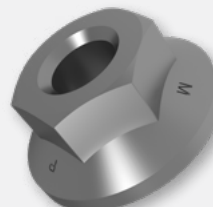

[AUSFN™  
Spinning Flare nut](#)

# SELF CLINCHING BLIND FASTENERS

PEM® brand self clinching blind fasteners provide permanently mounted blind threads in metal sheets as thin as .040"/1mm.

- Provides barrier to protect threads against foreign matter.
- Limits screw penetration, protecting internal components from potential damage.
- Available on special order with free-running locking thread feature.

PEM® self clinching blind fasteners employ the proven PEM® self clinching design and are easily installed into properly sized holes. Shanks of PEM® fasteners act as their own pilots. PEM® blind fasteners can be installed with any standard press applying squeezing forces between parallel surfaces.

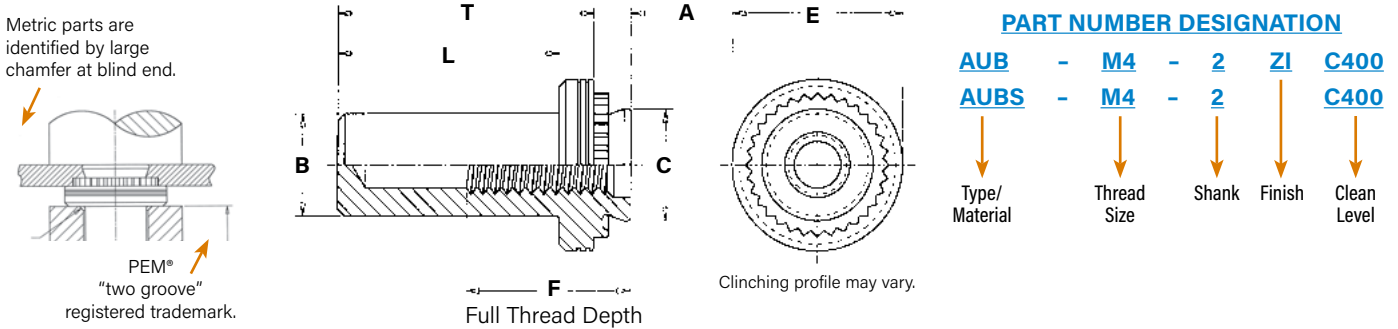

## AUB™/AUBS™ NUTS

All dimensions are in millimeters.

METRIC	Thread Size x Pitch	Type		Thread Code (1)	Shank Code	A (Shank) Max.	Min. Sheet Thickness	Hole Size in Sheet + 0.08	B Max.	C Max.	E ± 0.25	F Min.	L Max.	T ± 0.25	Min. Dist. Hole $\varnothing$ to Edge
		Fastener Material													
		Steel	Stainless Steel												
M3 x 0.5	AUB	AUBS	M3	1	0.97	1	4.22	3.84	4.2	6.35	5.3	8.5	9.6	4.8	
				2	1.38	1.4									
M4 x 0.7	AUB	AUBS	M4	1	0.97	1	5.41	5.2	5.38	7.95	7.1	9.8	11.2	6.9	
				2	1.38	1.4									
M5 x 0.8	AUB	AUBS	M5	1	0.97	1	6.35	6.02	6.33	8.75	7.1	9.8	11.2	7.1	
				2	1.38	1.4									
M6 x 1	AUB	AUBS	M6	1	1.38	1.4	8.75	7.8	8.73	11.1	7.8	12.7	14.3	8.6	
				2	2.21	2.29									

(1) PEM® AUB™ nuts are available on special order with a free-running locking thread feature allowing mating screw to turn freely until clamp load is applied. For more information, contact PEM® [Technical Support](#).

## MATERIAL AND FINISH SPECIFICATIONS

Type	Threads	Fastener Materials		Finishes			Clean Level (2)		For Use in Sheet Hardness: (3)	
	Internal, ASME B1.1, 2B / ASME B1.13M, 6H	Hardened Carbon Steel	300 Series Stainless Steel	Passivated and/or Tested Per ASTM A380	Zinc Plated per ASTM B633, SCl (5µm) Type III, Colorless (1)	Zinc Nickel Plated per ISO 19598 Fe//ZnNi8//Cn//TO 720h to red rust per ISO 9227 Salt Spray Test (1)	Max. Metallic Particle Size 400µm	Max. Metallic Particle Size 600µm	HRB 80 / HB 150 or less	HRB 70 / HB 125 or less
AUB	▪	▪			▪	▪	▪	▪	▪	
AUBS	▪		▪	▪			▪	▪		▪
Part Number Code For Finishes				None	ZI	ZN	C400	C600		

(1) See PEM [Technical Support](#) section of our web site for related plating standards and specifications.

(2) Parts requiring technical cleanliness will be considered a custom fastening solution. If technical cleanliness is not required on your part, do not include a clean level number when ordering.

(3) HRB - Hardness Rockwell "B" Scale. HB - Hardness Brinell.

# SELF CLINCHING BLIND FASTENERS

## INSTALLATION

1. Prepare properly sized mounting hole in the sheet. Do not perform any secondary operations such as deburring.
2. Place the barrel of the fastener into the anvil hole and place the mounting hole (preferably the punch side) over the shank of the fastener.
3. With the installation punch and anvil surfaces parallel, apply squeezing force until the flange contacts the mounting sheet. The sketch at the right indicates suggested tooling for applying these forces.

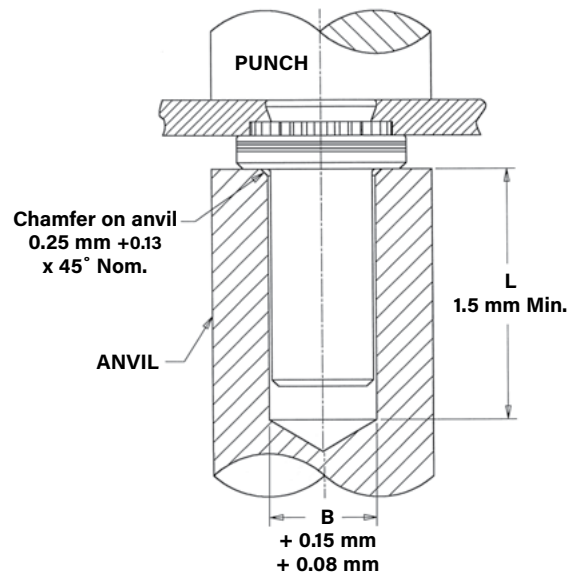

## PERFORMANCE DATA

METRIC	Thread Code	Shank Code	Sheet Thickness (mm)	Test Sheet Material					
				5052-H34 Aluminum			Cold-Rolled Steel		
				Installation (kN)	Pushout (N)	Torque-out (N-m)	Installation (kN)	Pushout (N)	Torque-out (N-m)
M3	1	1	71	400	1.15	11.1	550	1.5	
	2	1.4	9	750	1.47	14	1010	2.05	
M4	1	1	8.9	470	2.6	15.6	600	3.4	
	2	1.4	12.5	970	4	20	1250	5.1	
M5	1	1	9.3	480	3.6	17.8	620	4	
	2	1.4	14	845	5.7	25	1112	6.8	
M6	1	1.4	178	1400	10.2	25.7	1760	11.9	
	2	2.3							

## PEMSERTER® Installation Tooling

Type	Thread Code	Anvil Part Number	Punch Part Number
AUB/AUBS	M3	975200001	975200048
AUB/AUBS	M4	975200003	975200048
AUB/AUBS	M5	975200004	975200048
AUB/AUBS	M6	975200005	975200048

(1) Published installation forces are for general reference. Actual set-up and confirmation of complete installation should be made by observing proper seating of fastener as described in the installation steps. Other performance values reported are averages when all proper installation parameters and procedures are followed. Variations in mounting hole size, sheet material, and installation procedure may affect performance. Performance testing this product in your application is recommended. We will be happy to provide technical assistance and/or samples for this purpose.



# SELF CLINCHING NUTS

Self clinching nuts are installed by placing them in properly sized holes in sheets and applying a parallel squeezing force to the head of the nut. The sheet metal surrounding the head cold flows into an undercut thereby making the fastener an integral part of the sheet. A serrated clinching ring prevents the fastener from rotating after installation.

AUS™/AUSS™/AUCLS™/AUCLSS™ nuts provide load-bearing threads in thin sheets with high pushout and torque-out resistance. AUSTM™, PEM 300®, nuts provide strong load-bearing threads in stainless steel sheets as thin as 0.8 mm.

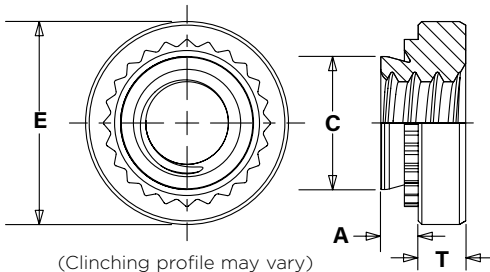
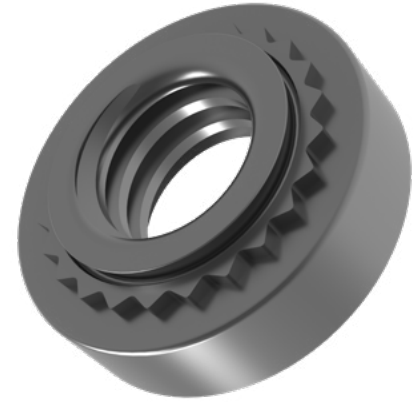

(Clinching profile may vary)  
Due to manufacturing procedure, parts may have a counterbore at shank end.

### PART NUMBER DESIGNATION

<a href="#">AUS</a>	-	<a href="#">M3</a>	-	<a href="#">1</a>	<a href="#">ZI</a>	<a href="#">C400</a>
<a href="#">AUSS</a>	-	<a href="#">M5</a>	-	<a href="#">1</a>	<a href="#">ZI</a>	<a href="#">C400</a>
<a href="#">AUCLS</a>	-	<a href="#">M3</a>	-	<a href="#">1</a>		<a href="#">C400</a>
<a href="#">AUCLSS</a>	-	<a href="#">M5</a>	-	<a href="#">1</a>		<a href="#">C400</a>
<a href="#">AUSP</a>	-	<a href="#">M3</a>	-	<a href="#">1</a>		<a href="#">C400</a>

↓	↓	↓	↓	↓	↓	↓
Type/ Material	Thread Size	Shank	Finish	Clean Level		

## AUS™/AUSS™/AUCLS™/AUCLSS™/AUSP™ NUTS

METRIC	Thread Size	Type			Thread Code	Shank Code	A (Shank) Max.	Rec. Min. Sheet Thickness (l)	Hole Size In Sheet +0.08	C Max.	E ±0.25	T ±0.25	Min. Dist. Hole To Edge
		Fastener Material											
		Carbon Steel	Stainless Steel	Hardened Stainless Steel									
M2 x 0.4	AUS	AUCLS	AUSP	M2	0 <sup>(2)</sup>	0.77	0.8	4.22	4.2	6.35	1.5	4.8	
					1	0.97	1						
					2	1.38	1.4						
M2.5 x 0.45	AUS	AUCLS	AUSP	M2.5	0	0.77	0.8	4.22	4.2	6.35	1.5	4.8	
					1	0.97	1						
					2	1.38	1.4						
M3 x 0.5	AUS	AUCLS	AUSP	M3	0	0.77	0.8	4.22	4.2	6.35	1.5	4.8	
					1	0.97	1						
					2	1.38	1.4						
M3.5 x 0.6	AUS	AUCLS	—	M3.5	0	0.77	0.8	4.75	4.73	7.11	1.5	5.6	
					1	0.97	1						
					2	1.38	1.4						
M4 x 0.7	AUS	AUCLS	AUSP	M4	0	0.77	0.8	5.41	5.38	7.87	2	6.9	
					1	0.97	1						
					2	1.38	1.4						
M5 x 0.8	AUSS	AUCLSS	AUSP	M5	0	0.77	0.8	6.35	6.33	8.64	2	7.1	
					1	0.97	1						
					2	1.38	1.4						
M6 x 1	AUS <sup>(3)</sup>	AUCLS	AUSP	M6	00 <sup>(2)</sup>	0.89	0.92	8.75	8.73	11.18	4.08	8.6	
					0 <sup>(2)</sup>	1.15	1.2						
					1	1.38	1.4						
					2	2.21	2.29						
M8 x 1.25	AUS <sup>(3)</sup>	AUCLS	AUSP	M8	1	1.38	1.4	10.5	10.47	12.7	5.47	9.7	
					2	2.21	2.29						
M10 x 1.5	AUS	AUCLS	AUSP	M10	1	2.21	2.29	14	13.97	17.35	7.48	13.5	
					2 <sup>(2)</sup>	3.05	3.18						
M12 x 1.75	AUS	—	—	M12	1	3.05	3.18	17	16.95	20.57	8.5	16	

- (1) For maximum performance, we recommend that you use the maximum shank length for your sheet thickness.
- (2) This shank code not available for AUSP nuts.
- (3) This thread size AUS nut, with a -2 shank code, can be installed successfully without the need to pre punch a mounting hole in a separate operation.

# SELF CLINCHING NUTS

## MATERIAL AND FINISH SPECIFICATIONS

Type	Threads	Fastener Materials			Finishes <sup>(1)</sup>			Clean Level <sup>(2)</sup>		For use in Sheet Hardness <sup>(5)</sup>		
	Internal ASME B1.1 2B/ASME B1.13M, 6H	Hardened Carbon Steel	300 Series Stainless Steel	Age Haerdened A286 Stainless Steel	Passivated and/or Tested per ASTM A380	Zinc Plated per ASTM B633, SC1 (5µm) Type III, Colorless	Zinc Nickel Plated per ISO 19598 Fe//ZnNi8//Cr//TO 720h to red rust per ISO 9227 Salt Spray Test	Max. Metallic Particle Size 400µm	Max. Metallic Particle Size 600µm	HRB 90 / HB 192 or less	HRB 80 / HB 150 or less	HRB 70 / HB 125 or less
AUS	▪	▪				▪	▪	▪	▪		▪	
AUSS	▪	▪				▪	▪	▪	▪		▪	
AUCLS	▪		▪		▪			▪	▪			▪
AUCLSS	▪		▪		▪			▪	▪			▪
AUSP	▪			▪				▪	▪	▪(3)(4)		
Part number codes for finishes					None	ZI	ZN	C400	C600			

(1) See PEM® Technical Support section of our web site for related plating standards and specifications.

(2) Parts requiring technical cleanliness will be considered a custom fastening solution. If technical cleanliness is not required on your part, do not include a clean level number when ordering.

(3) Panel material should be in the annealed condition.

(4) Fasteners should not be installed adjacent to bends or other highly cold-worked areas.

(5) HRB - Hardness Rockwell "B" Scale. HRC - Hardness Rockwell "C" Scale. HB - Hardness Brinell.

## INSTALLATION - AUCLSTM/AUCLSS™/AUS™/AUSS™

1. Prepare properly sized mounting hole in sheet. Do not perform any secondary operations such as deburring.
2. Place fastener into the anvil hole and place the mounting hole (preferably the punch side) over the shank of the fastener as shown in diagram to the right.
3. With installation punch and anvil surfaces parallel, apply squeezing force until the head of the nut comes into contact with the sheet material.

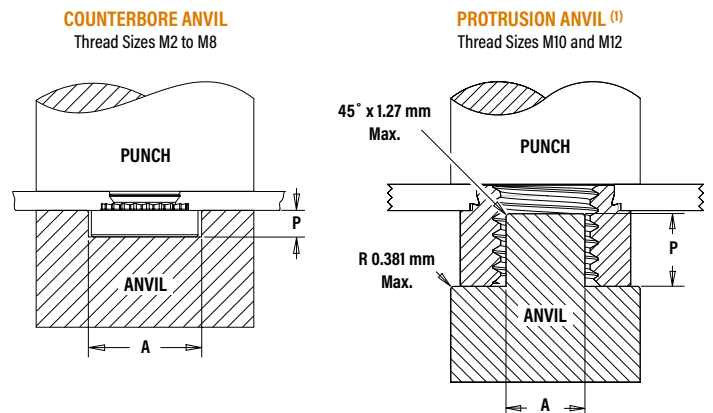

## PEMSERTER® Installation Tooling

METRIC	Thread Code	Anvil Dimensions (mm)		Anvil Part Number	Punch Part Number
		A ±0.05	P ±0.13		
	M2/M3	6.78	1.14	975200034	975200048
	M3.5	7.57	1.14	975200035	975200048
	M4	8.38	1.78	975200036	975200048
	M5	9.17	1.78	975200037	975200048
	M6	11.53	3.81	975200038	975200048
	M8	13.08	5.08	975200039	975200048
	M10	7.62	6.35	8005682 <sup>(1)</sup>	975200901400
	M12	9.53	8.76	975200900300 <sup>(1)</sup>	975200901400

# SELF CLINCHING NUTS

## INSTALLATION - AUSP™

1. Prepare properly sized mounting hole in sheet. Do not perform any secondary operations such as deburring.
2. Place fastener into the recommended counterbore anvil hole and place the mounting hole (preferably the punch side) over the shank of the fastener as shown in diagram.
3. With installation punch and anvil surfaces parallel, apply squeezing force until the head of the nut comes into contact with the sheet material.

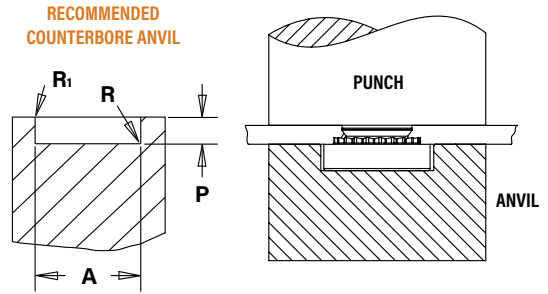

(1) For best results, we recommend using the installation punch and anvil shown. Deviations from recommended installation tooling may result in sheet distortion and reduced performance.

**NOTE:** Variations in hole preparation, installation tooling, installation force, and sheet material type, thickness, and hardness will affect both performance and tooling life.

## PEMSERTER® Installation Tooling

	Thread Code	Anvil Dimensions (mm)				Anvil Part Number	Punch Part Number
		A ±0.05	P -0.03	R Max.	R <sub>1</sub> +0.13		
METRIC	M2	6.48	1.63	0.25	0.13	8012821	975200048
	M2.5-0	6.48	1.42	0.25	0.13	8019477	
	M2.5-1,-2	6.48	1.63	0.25	0.13	8012821	
	M3	6.48	1.63	0.25	0.13	8012821	
	M3.5	7.26	1.63	0.25	0.13	8012822	
	M4	8.05	2.08	0.25	0.13	8012823	
	M5	8.84	2.08	0.25	0.13	8012824	
	M6	11.25	4.14	0.25	0.13	8012825	
	M8	12.83	5.41	0.25	0.13	8015360	8003076
	M10	17.58	7.47	0.25	0.13	8015886	

## PERFORMANCE DATA<sup>(1)</sup>

### AUS™/AUCLSTM™/AUCLSS™ NUTS

METRIC	Type	Thread Code	Shank Code	Test Sheet Material <sup>(2)</sup>	Installation (kN)	Pushout (N)	Torque-out (N-m)
	AUS AUCLS	M2	M2.5	0	5052-H34 Aluminum	6.7-8.9	280
1				400	1.13		
2				750	1.47		
0				Cold-rolled Steel	470		1.47
1					550		1.7
2					1010		2.03
AUS AUCLS		M3.5	0	5052-H34 Aluminum	11.2-13.5	280	1.8
			1	400		1.92	
			2	840		2.5	
			0	Cold-rolled Steel		480	1.8
			1			570	2.3
			2			1210	2.3
AUS AUCLS	M4	0	5052-H34 Aluminum	11.2-13.4	300	2.37	
		1	470		2.6		
		2	970		4		
		0	Cold-rolled Steel		490	2.95	
		1			645	4	
		2			1250	5.1	
AUS AUCLSS	M5	0	5052-H34 Aluminum	11.2-15.6	300	3	
		1	480		3.6		
		2	845		5.7		
		0	Cold-rolled Steel		530	3.6	
		1			800	4.5	
		2			1420	6.8	
AUS AUCLS	M6	00	5052-H34 Aluminum	18-32	750	6.5	
		0			970	7.9	
		1			1580	10.2	
		2	Cold-rolled Steel		14.1		
		00			900	10	
		0			1380	13	
1	1760	17					
AUS AUCLS	M8	1	5052-H34 Aluminum	18-32	1570	13.6	
		2	18.1				
		1	Cold-rolled Steel			18.7	
		2				20.3	
AUS AUCLS	M10	1	5052-H34 Aluminum	22-36	1760	32.7	
		2	36.2				
		1	Cold-rolled Steel			2020	
		2					
AUS	M12	1	5052-H34 Aluminum	31-40	2113	39.5	
		1	Cold-rolled Steel	44-67	4670	83.1	

### AUSP™ NUTS

METRIC	Type	Thread Code	Shank Code	Test Sheet Material	Installation (kN)	Pushout (N)	Torque-out (N-m)
	AUSP	M2	M2	1	304 Stainless Steel	40	725
2				44.5		1290	2.03
0				35.6		575	1.58
M2.5		M2.5	1	304 Stainless Steel	40	725	1.92
			2		44.5	1290	2.03
			0		35.6	575	1.58
M3		M3	1	304 Stainless Steel	40	725	1.92
			2		44.5	1290	2.03
			0		40	645	3.38
M4		M4	1	304 Stainless Steel	44.5	800	4.18
			2		49	1600	5.08
			0		42.3	800	3.95
M5	M5	1	304 Stainless Steel	46.7	1025	5.08	
		2		51.2	1775	6.77	
		0		60	2000	17	
M6	M6	1	304 Stainless Steel	60	2600	19	
		2		66	2100	19	
M8	M8	1	304 Stainless Steel	80	4500	23	
		2					
M10	M10	1	304 Stainless Steel	80	2150	38	

(1) Published installation forces are for general reference. Actual set-up and confirmation of complete installation should be made by observing proper seating of fastener as described in the installation steps. Other performance values reported are averages when all proper installation parameters and procedures are followed. Variations in mounting hole size, sheet material, and installation procedure may affect performance. Performance testing this product in your application is recommended. We will be happy to provide technical assistance and/or samples for this purpose.

# SELF CLINCHING STUDS AND PINS

## AUFH™/AUFHS™/AUFHA™ STUDS

AUFH™/AUFHS™/AUFHA™ (flush-head) studs are available in aluminum, steel, or stainless steel. PEM® standard flush-head studs are designed to be installed in sheets as thin as 1 mm.

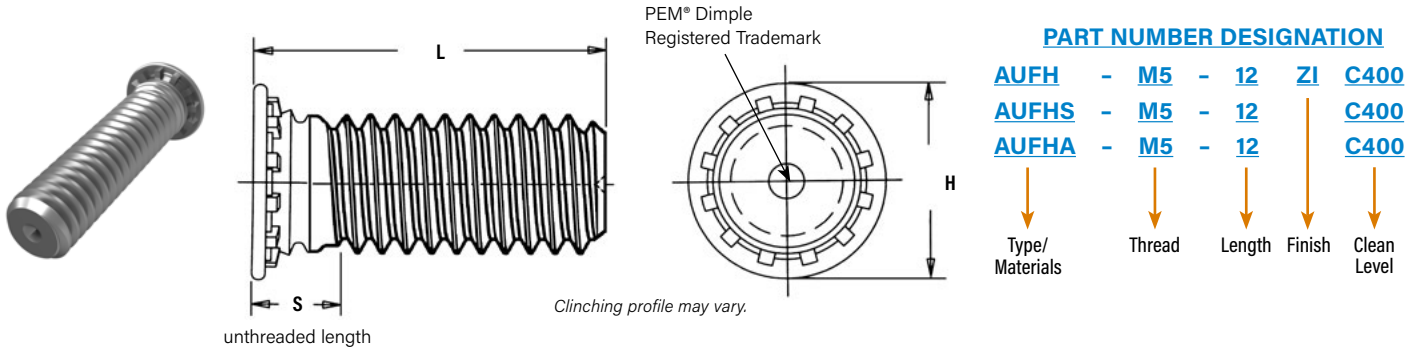

All dimensions are in millimeters.

METRIC	Thread Size x Pitch	Type			Thread Code	Length Code "L" ±0.4 (Length Code in millimeters)										Min. Sheet Thickness (1)	Hole Size in Sheet +0.08	H ± 0.4	S Max. (2)	Max. Hole in Attached Parts	Dist. Hole to Edge
		Fastener Material																			
		Steel	Stainless Steel	Aluminum																	
	M2.5 x 0.45	AUFH	AUFHS	AUFHA	M2.5	6	8	10	12	15	18	—	—	—	—	1	2.5	4.1	1.95	3.1	5.4
	M3 x 0.5	AUFH	AUFHS	AUFHA	M3	6	8	10	12	15	18	20	25	—	—	1	3	4.6	2.1	3.6	5.6
	M3.5 x 0.6	AUFH	AUFHS	AUFHA	M3.5	6	8	10	12	15	18	20	25	30	—	1	3.5	5.3	2.25	4.1	6.4
	M4 x 0.7	AUFH	AUFHS	AUFHA	M4	6	8	10	12	15	18	20	25	30	35	1	4	5.9	2.4	4.6	7.2
	M5 x 0.8	AUFH	AUFHS	AUFHA	M5	—	8	10	12	15	18	20	25	30	35	1	5	6.5	2.7	5.6	7.2
	M6 x 1	AUFH	AUFHS	AUFHA	M6	—	—	10	12	15	18	20	25	30	35	1.6	6	8.2	3	6.6	7.9
	M8 x 1.25	AUFH	AUFHS	—	M8	—	—	—	12	15	18	20	25	30	35	2.4	8	9.6	3.7	8.6	9.6

## AUHFE™/AUTHFE™ STUDS

AUHFE™/AUTHFE™ (heavy-duty) studs Provides maximum pull through in sheets as thin as 0.8 mm.

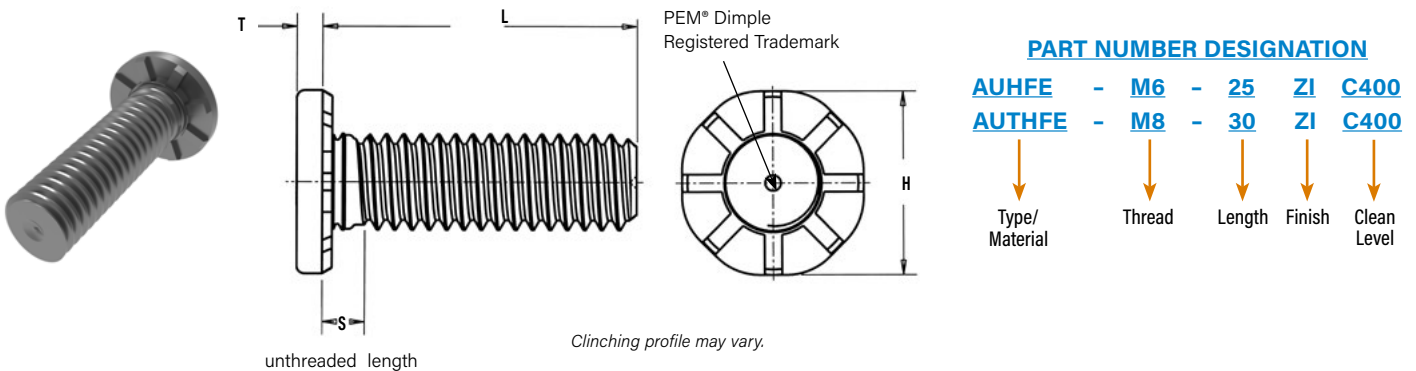

All dimensions are in millimeters.

METRIC	Thread Size x Pitch	Type		Thread Code	Length Code "L" ±0.4 (Length Code in millimeters)										Min. Sheet Thickness (1)	Hole Size in Sheet +0.13	H ±0.25	S Max. (2)	T Max.	Max. Hole in Attached Parts	Min. Dist. Hole to Edge
		Fastener Material																			
		Steel																			
	M5 x 0.8	AUHFE		M5	15	20	25	30	35	40	50	1	5	9.6	2.6	1.35	7.3	10			
	M6 x 1	AUHFE		M6	15	20	25	30	35	40	50	1	6	11.35	2.8	1.7	8.3	11.5			
		AUTHFE										0.8			2.62						
	M8 x 1.25	AUHFE		M8	15	20	25	30	35	40	50	1.5	8	15.3	3.3	2.13	10.3	14.5			
		AUTHFE										0.8			2.9				2.54	15	

(1) See installation section for installation tool requirements.

Tensile strength: 900 MPa

(2) Threads are gaugeable to within 2 pitches of the "S" Max. dimension. A class 3B/5H maximum material commercial nut shall pass up to the "S" Max. dimension.

# SELF CLINCHING STUDS AND PINS

## AUHFH™/AUHFHS™/AUHFHB™ STUDS

AUHFH™/AUHFHS™ (heavy-duty) studs have a large head which projects above the sheet material to distribute the axial tightening force over a large area thereby improving pull through resistance. AUHFHB™ (heavy-duty BUSBAR®) studs are ideal for applications which demand superior electrical/mechanical attachment points.

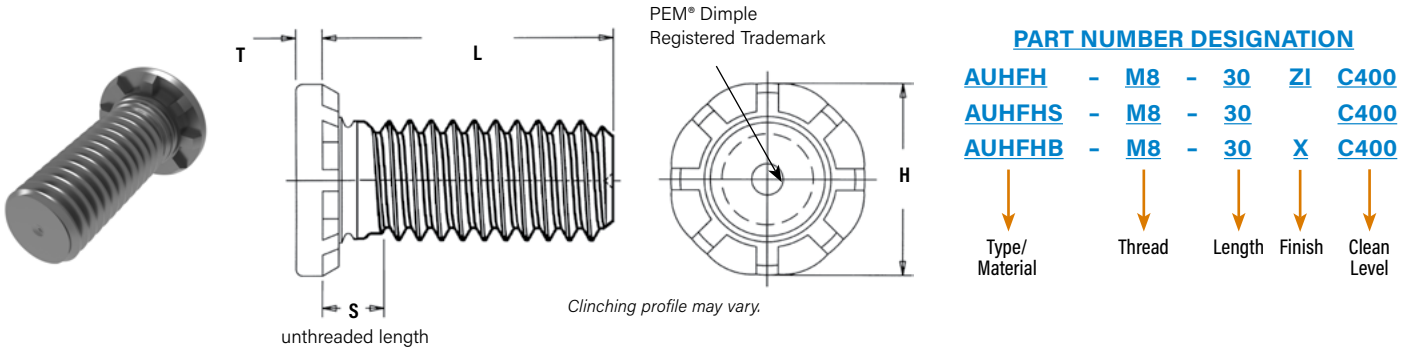

All dimensions are in millimeters.

**Tensile strength:** AUHFH - 900 MPa / AUHFHS - 515 MPa / AUHFHB - 415 MPa.

METRIC	Thread Size x Pitch	Type			Thread Code	Length code "L" ±0.4 (Length Code in millimeters)						Min. Sheet Thickness (2)	Hole Size in Sheet +0.13	H ±0.25	S Max. (3)	T Max.	Max. Hole in Attached Parts	Min. Dist. Hole to Edge
		Fastener Material																
		Steel	Stainless Steel	Phosphor Bronze(1)														
M5 x 0.8	AUHFH	AUHFHS	AUHFHB	M5	15	20	25	30	35	40	50	1.3	5	7.8	2.7	1.14	6.4	10.7
M6 x 1	AUHFH	AUHFHS	AUHFHB	M6	15	20	25	30	35	40	50	1.5	6	9.4	2.8	1.27	7.5	11.5
M8 x 1.25	AUHFH	AUHFHS	AUHFHB	M8	15	20	25	30	35	40	50	2	8	12.5	3.5	1.78	9.5	12.7
M10 x 1.5	AUHFH	AUHFHS	AUHFHB	M10	15	20	25	30	35	40	50	2.3	10	15.7	4.1	2.29	11.5	13.7

- (1) The electrical resistance (tested at 10 amps DC) between phosphor bronze studs and copper busbars is below 104μ ohms and 62μ ohms for the M5 and M10 thread sizes respectively, after repeated thermal and mechanical cycling. For complete electrical resistance test data for type AUHFHB studs installed in copper, see bulletin entitled "Electrical Resistance of AUHFHB Studs Installed in Copper" on our website.
- (2) See installation section for installation tool requirements.
- (3) Threads are gaugeable to within 2 pitches of the "S" Max. dimension. A class 3B/5H maximum material commercial nut shall pass up to the "S" Max. dimension.

## MATERIAL AND FINISH SPECIFICATIONS

Type	Threads (1)	Fastener Materials				Finishes				Clean Level (2)		For Use in Sheet Hardness (4)					
		Hardened Carbon Steel	Aluminum (plain finish)	300 Series Stainless Steel	CDA 510 Phosphor Bronze	No Finish (5)	Zinc Plated per ASTM B633, SC1 (5um), Type III, Colorless (3)	Passivated and/or Tested Per ASTM A380	Zinc Nickel Plated per ISO 19598 Fe//ZnNi8//Cr//TO 720h to red rust per ISO 9227 Salt Spray Test (3)	Max. Metallic Particle Size 400μm	Max. Metallic Particle Size 600μm	HRB 50/ HB 82	HRB 55/ HB 83	HRB 70/ HB 125	HRB 80/ HB 150	HRB 85/ HB 165	
AUFH	▪	▪		▪		▪			▪	▪						▪	
AUFHS	▪			▪				▪		▪							
AUFHA	▪		▪			▪					▪						
AUHFE	▪	▪							▪		▪						▪
AUTHFE	▪	▪							▪		▪						▪
AUHFH	▪	▪							▪		▪						▪
AUHFHB	▪				▪						▪					▪	
AUHFHS	▪				▪						▪						
Part Number Codes for Finishes						X	ZI	None	ZN	C400	C600						

- (1) For plated studs, Class 2A/6g, the maximum major and pitch diameter, after plating, may equal basic sizes and be gauged to Class 3A/4h. Per ASME B1.1, Section 7, Paragraph 7.2 and ASME B1.13M, Section 8, paragraph 8.2.
- (2) Parts requiring technical cleanliness will be considered a custom fastening solution. If technical cleanliness is not required on your part, do not include a clean level number when ordering.
- (3) See PEM® Technical Support section of our web site for related plating standards and specifications.
- (4) HRB - Hardness Rockwell "B" Scale. HB - Hardness Brinell.
- (5) "X" suffix studs may have pitch diameters and major diameters below 2A/6g minimum size, per ANSI B1.1, Section 7, and B1.13M, Section 8 to allow for minimum of 0.0002" / 0.0051 mm of plating.

# SELF CLINCHING STUDS AND PINS

## INSTALLATION - AUFH™/AUFHS™/AUFHA™ STUDS

1. Prepare properly sized mounting hole in sheet. Do not perform any secondary operations such as deburring.
2. Insert stud through mounting hole (punch side) of sheet and into anvil hole.
3. With punch and anvil surfaces parallel, apply squeezing force to embed the head of the stud flush in the sheet. In most cases, when using sheets 1.51 mm and thicker, the anvil requires only a straight thru hole to accommodate the stud (see illustrations below for details). For sheets less than 1.51 mm, the hole requires a countersink with dimension A at the top to provide for metal flow around the shank of the stud.

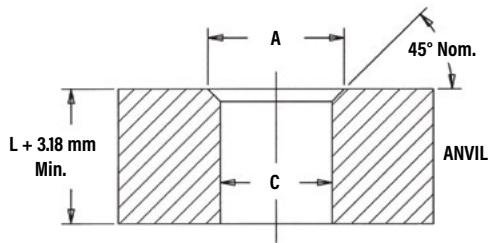
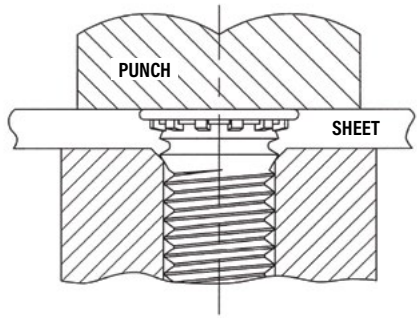

Tooling for sheet thicknesses less than 1.51 mm with M2.5 thru M5 thread sizes and less than 2.36 mm for M6 threads.

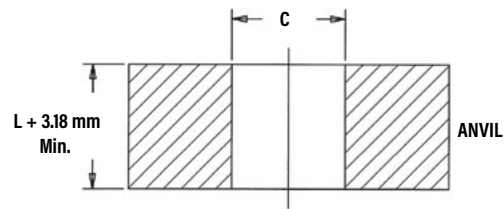
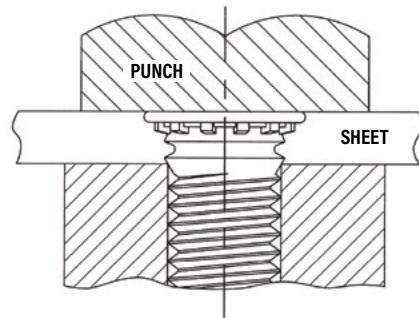

Tooling for sheet thicknesses 1.51 mm and greater with M2.5 thru M5 thread sizes and .2.36 mm and greater for 1M6 and M8 threads.

## PEMSERTER® Installation Tooling

	Thread Code	Anvil Dimensions (mm)		Anvil Part No. For Sheets > 1.51 mm	Anvil Part No. For Sheets ≤ 1.5 mm	Punch Part Number	
		A + 0.1	C + 0.08				
METRIC	M2.5	3.1	2.53	970200300300	970200493300	975200048	
	M3	3.6	3.03	970200229300	970200242300		
	M3.5	4.1	3.53	970200007300	970200243300		
	M4	4.6	4.03	970200019300	970200244300		
	M5	5.6	5.03	970200020300	970200247300		
					For Sheets > 2.36 mm	For Sheets ≤ 2.36 mm	975200048
	M6	6.6	6.03	970200230300	970200248300		
	M8	8.6	8.03	970200231300	—		

# SELF CLINCHING STUDS AND PINS

## INSTALLATION - AUHFH™/AUHFHB™/AUHFHS™ STUDS

1. Prepare properly sized mounting hole in sheet. Do not perform any secondary operations such as deburring.
2. Insert stud through mounting hole (punch side) of sheet and into anvil hole.
3. With punch and anvil surfaces parallel, apply squeezing force on the punch sufficient only to embed the ribs on the head of the stud into the sheet. The standard punch design provides clearance for the stud head and reduces chances of over squeezing.

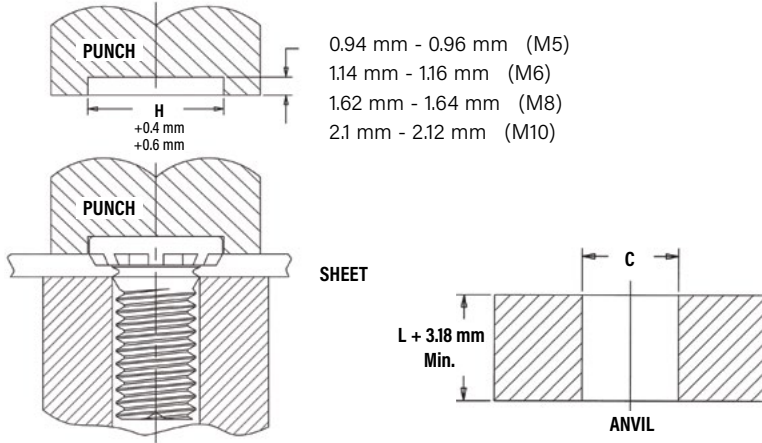

### PEMSERTER® Installation Tooling

METRIC	Thread Code	Anvil Dimensions (mm)	Anvil Part Number	Punch Part Number
		C + 0.08		
	M5	5.03	970200020300	970200311400
	M6	6.03	970200230300	970200312400
	M8	8.03	970200231300	970200313400
	M10	10.03	970200402300	970200491400

## INSTALLATION - AUHFE™ STUDS

1. Prepare properly sized mounting hole in sheet. Do not perform any secondary operations such as deburring.
2. Insert stud through mounting hole (punch side) of sheet and into anvil hole.
3. With punch and anvil surfaces parallel, apply squeezing force on the punch sufficient only to embed the ribs on the head of the stud into the sheet.

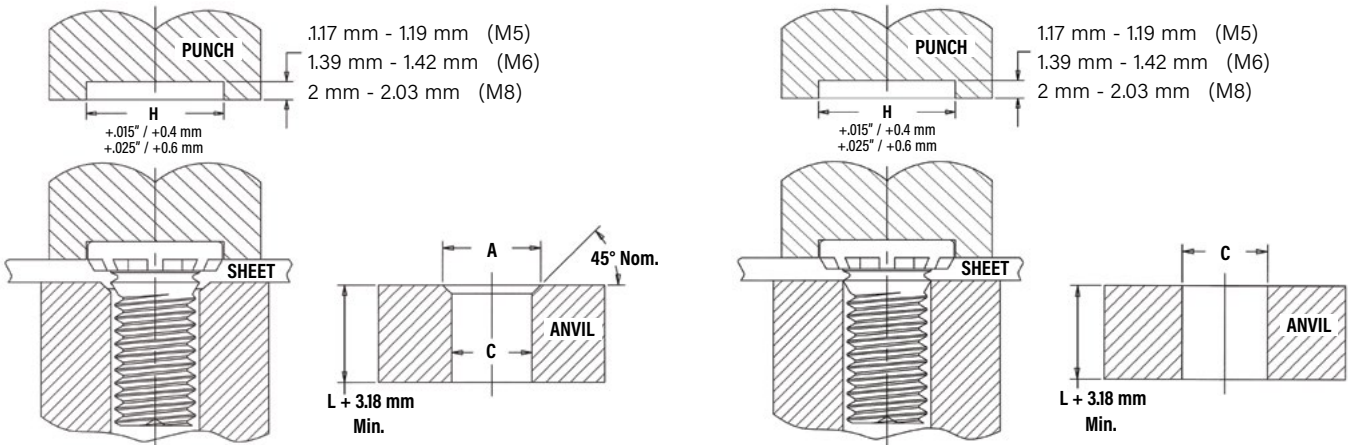

Tooling for sheet thicknesses less than 1.51 mm with M5 and M6 thread sizes and less than 1.9 mm with M8 threads.

Tooling for sheet thicknesses 1.51 mm and greater with M5 and M6 thread sizes and 1.9 mm and greater with M8 threads.

### PEMSERTER® Installation Tooling

METRIC	Thread Code	Anvil Dimensions (mm)		Anvil Part No. For Sheets > 1.51 mm	Anvil Part No. For Sheets 1 mm - 1.51 mm	Punch Part Number
		A + 0.1	C + 0.08			
	M5	5.6	5.03	970200020300	8003704	8003710
	M6	6.6	6.03	970200230300	8003705	8003711
				For Sheets > 1.9 mm	For Sheets 1.5 - 1.9 mm	
	M8	8.6	8.03	970200231300	8003706	8003712

# SELF CLINCHING STUDS AND PINS

## INSTALLATION - AUTHFE™ STUDS

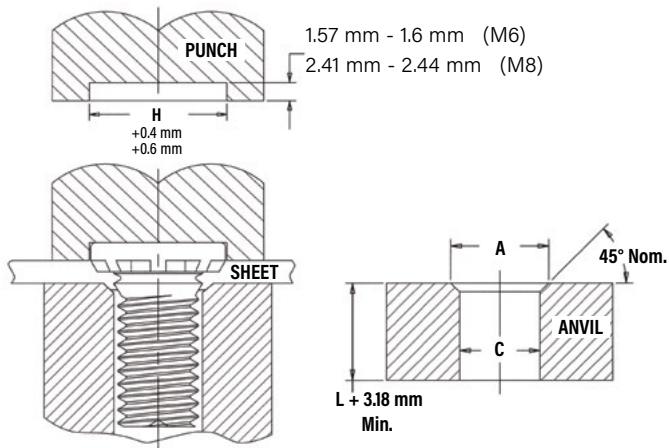

Tooling for sheet thicknesses less than 1.31 mm with M6 thread sizes, and less than 1.71 mm with M8 thread sizes.

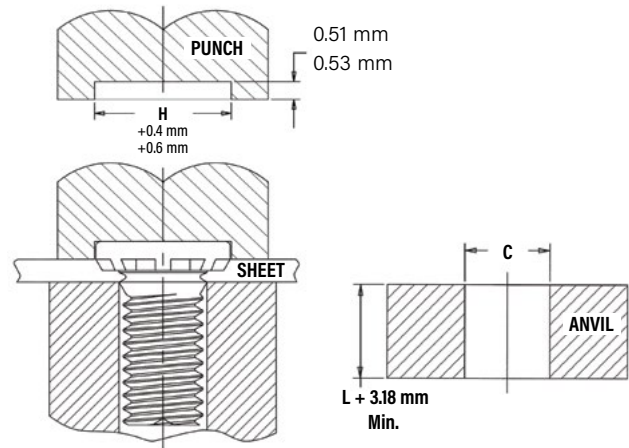

Tooling for sheet thicknesses 1.31 mm and greater with M6 and 1.71 mm thread sizes and greater with M8 threads.



## PEMSERTER® Installation Tooling

METRIC	Thread Code	Anvil Dimensions (mm)		Anvil Part No. For Sheets > 1.3 mm	Anvil Part No. For Sheets 0.8 - 1.3 mm	Punch Part Number
		A + 0.1	C + 0.08			
	M6	7.25	6.03	970200230300	8019888	8019892
				For Sheets > 1.7 mm	For Sheets 0.8 - 1.7 mm	
	M8	9.55	8.03	970200231300	8019889	8019893

# SELF CLINCHING STUDS AND PINS

Published installation forces are for general reference. Actual set-up and confirmation of complete installation should be made by observing proper seating of fastener as described in the installation steps. Other performance values reported are averages when all proper installation parameters and procedures are followed. Variations in mounting hole size, sheet material, and installation procedure may affect performance. Performance testing this product in your application is recommended. We will be happy to provide technical assistance and/or samples for this purpose.

## PERFORMANCE DATA - AUFH™/AUFHS™ STUDS

METRIC	Thread Code	Rec. Nut Tightening Torque (N-m) (1)	Type	Test Sheet Thickness & Material	Sheet Hardness HRB	Installation (kN)	Pushout (N)	Torque-out (N-m)	Pull Thru (N)
	M2.5		0.78	AUFH	1.6 mm Aluminum	29	8.9	465	1.0
		0.48	AUFHS	1.6 mm Aluminum	29	11.6	465	0.8	1820
		0.84	AUFH	1.5 mm Steel	59	11.1	740	1.0	2800
		0.48	AUFHS	1.5 mm Steel	59	13.8	740	0.8	1820
M3		1.1	AUFH	1.6 mm Aluminum	29	12.9	600	1.7	3150
		0.81	AUFHS	1.6 mm Aluminum	29	12.9	600	1.3	2570
		1.4	AUFH	1.5 mm Steel	59	14.7	820	1.7	3840
		0.77	AUFHS	1.5 mm Steel	59	14.7	820	1.3	2440
M3.5		1.6	AUFH	1.6 mm Aluminum	29	15.6	800	1.7	3780
		1.3	AUFHS	1.6 mm Aluminum	29	15.6	800	1.7	3445
		1.6	AUFH	1.5 mm Steel	59	22.3	1335	2.8	3780
		1.3	AUFHS	1.5 mm Steel	59	22.3	1335	2.0	3445
M4		2.1	AUFH	1.6 mm Aluminum	29	20	975	2.9	4448
		1.8	AUFHS	1.6 mm Aluminum	29	22.3	975	2.9	4180
		2.7	AUFH	1.5 mm Steel	59	28.9	1780	4.2	5650
		2	AUFHS	1.5 mm Steel	59	26.7	1780	2.9	4775
M5		3.1	AUFH	1.6 mm Aluminum	29	24.5	1070	3.5	5170
		2.5	AUFHS	1.6 mm Aluminum	29	24.5	1070	3.5	4760
		3.8	AUFH	1.5 mm Steel	59	33.4	2000	6.5	6270
		3.2	AUFHS	1.5 mm Steel	59	32.5	2000	6.3	6000
M6		7.3	AUFH	2.4 mm Aluminum	28	28.9	1660	7.3	10200
		5.7	AUFHS	2.4 mm Aluminum	28	28.9	1660	7.3	9090
		8.1	AUFH	2.2 mm Steel	46	44.5	2560	11.3	11300
		6.7	AUFHS	2.2 mm Steel	46	44.5	2560	10.1	10600
M8		10	AUFH	2.4 mm Aluminum	28	29.8	1910	11.3	10500
		8	AUFHS	2.4 mm Aluminum	28	29.8	1910	11.3	9540
		15	AUFH	2.4 mm Steel	46	44.5	2890	19.2	15450
	11	AUFHS	2.4 mm Steel	46	49.8	2890	17.5	13630	

## PERFORMANCE DATA - AUFHA™ STUDS

METRIC	Thread Code	Rec. Nut Tightening Torque (N-m) (1)	Type	Test Sheet Thickness & Material	Sheet Hardness HR15T	Installation (kN)	Pushout (N)	Torque-out (N-m)	Pull Thru (N)
	M3		0.54	AUFHA	1.55 mm 5052-H34 Aluminum	74	10.7	575	0.5
M4		0.96	AUFHA	1.55 mm 5052-H34 Aluminum	75	14.3	775	1.35	2000
M5		1.5	AUFHA	1.55 mm 5052-H34 Aluminum	75	15.2	900	2.6	2500
M6		3.2	AUFHA	1.6 mm 5052-H34 Aluminum	75	24.5	1500	5.3	4500

(1) Tightening torque shown is a theoretical value calculated to induce a load of 75% of minimum axial yield strength of the stud with an assumed K value or nut factor equal to 0.20. In some applications tightening torque may need to be adjusted based on the actual K value.

# SELF CLINCHING STUDS AND PINS

## PERFORMANCE DATA - AUHFE™ STUDS

METRIC	Thread Code	Rec. Nut Tightening Torque (N-m) <sup>(1)</sup>	Test Sheet Thickness and Material <sup>(2)</sup> (mm)	Sheet Hardness HRB	Installation (kN) <sup>(3)</sup>	Pushout (N)	Torque-out (N-m)	Tensile Strength (kN) <sup>(4)</sup>	Pull Thru (kN)	Test Bushing Hole Size For Pull Thru Tests
	M5		5.8	1 mm Aluminum	27	37.7	690	8.1	12.8	9.7
		6.4	1 mm Cold-rolled Steel	67	51.1	1350	8.1	12.8	10.6	
M6		10	1 mm Aluminum	27	39	750	11.8	18.1	14.2	8.2
		11	1 mm Cold-rolled Steel	67	60	1400	14.4	18.1	15.5	
M8		24	1.5 mm Aluminum	22	42	1230	23.5	32.9	25	10.3
		26	1.5 mm Cold-rolled Steel	65	71.1	2400	33.9	32.9	27.5	

## PERFORMANCE DATA - AUTHFE™ STUDS

METRIC	Thread Code	Rec. Nut Tightening Torque (N-m) <sup>(1)</sup>	Test Sheet Thickness and Material <sup>(2)</sup> (mm)	Sheet Hardness HRB	Installation (kN) <sup>(3)</sup>	Pushout (N)	Torque-out (N-m)	Tensile Strength (kN) <sup>(4)</sup>	Pull Thru (kN)	Test Bushing Hole Size For Pull Thru Tests
	M6		9	0.8 mm Aluminum	38	39.2	550	7.3	18.1	13
		10	0.8 mm Cold-rolled Steel	47	60.1	886	13.4	18.1	14.3	
M8		27	0.8 mm Aluminum	44	56	582	12.2	32.9	27.8	10.3
		27	0.8 mm Cold-rolled Steel	47	71.2	881	13.1	32.9	28.1	

## PERFORMANCE DATA - AUHFH™/AUHFHS™/AUHFHB™ STUDS

METRIC	Thread Code	Type	Rec. Nut Tightening Torque (N-m) <sup>(1)</sup>	Test Sheet Thickness and Material	Sheet Hardness HRB	Installation (kN) <sup>(2)</sup>	Pushout (N)	Torque-out (N-m)	Tensile Strength (kN)
	M5	AUHFH		7.7	1.5 mm Aluminum	15	13	800	5.4
AUHFH			7.7	1.5 mm Steel	65	26	1500	7.6	12.8
AUHFHS			3.8	1.62 mm Aluminum	35	12.4	800	5.4	7.3
AUHFHS			3.8	1.47 mm Steel	54	21.7	1500	6.4	7.3
AUHFHB			2.7	1.5 mm Copper CDA-110	28	15.6	1115	3.4	5.9
M6	AUHFH		13	1.5 mm Aluminum	43	29	1270	14	18.1
	AUHFH		13	1.5 mm Steel	59	33	1750	14	18.1
	AUHFHS		6.5	1.62 mm Aluminum	35	15.4	1270	11	10.3
	AUHFHS		6.5	1.6 mm Steel	45	24.6	1750	11	10.3
	AUHFHB		4.5	1.5 mm Copper CDA-110	28	25.3	1600	6.7	8.3
M8	AUHFH		32	2.3 mm Aluminum	39	35.6	1700	30	32.9
	AUHFH		32	2.3 mm Steel	58	44.5	2200	30	32.9
	AUHFHS		16	2.23 mm Aluminum	44	24.4	1700	20	18.8
	AUHFHS		16	2.48 mm Steel	43	37.8	2100	20	18.8
M10	AUHFHB		11	3.2 mm Copper CDA-110	32	33	2250	15.3	15.1
	AUHFH		63	2.3 mm Aluminum	39	53.3	2445	36	52.2
	AUHFH		63	2.3 mm Steel	58	71.2	3470	49	52.2
	AUHFHS		31	2.3 mm Aluminum	44	44.4	2445	36	29.9
	AUHFHS		31	2.3 mm Steel	44	57.7	3470	36	29.9
	AUHFHB		22	3.2 mm Copper CDA-110	32	53.3	2500	25	24

(1) Tightening torque shown is a theoretical value calculated to induce a load of 75% of minimum axial yield strength of the stud with an assumed K value or nut factor equal to 0.20. In some applications tightening torque may need to be adjusted based on the actual K value.

(2) See [tech sheet](#) on our website for performance data of PEM® Types AUHFE™ and AUTHFE™ studs installed into copper sheets.

(3) Installation controlled by proper cavity depth in punch.

(4) Head size is adequate to ensure failure in threaded area when tested with industry standard tensile bushing diameter.

# SELF CLINCHING STANDOFFS

PEM® self clinching standoffs, which use the proven self clinching design, provide ideal solutions for applications where mounting, spacing or stacking of panels, boards or components are required. Pressed into round holes, these fasteners mount permanently into metal sheets as thin as 0.63 mm.

Specially designed AUSO4™ and AUBSO4™ standoffs are made from hardened stainless steel and are ideal for clinching into stainless steel sheets. An optional nickel plating is now available if product is expected to be used in a corrosive environment.

For more information on the proper use of PEM® self clinching standoffs, check our website for Tech Sheet [PEM® - REF/Standoff Basics](#).

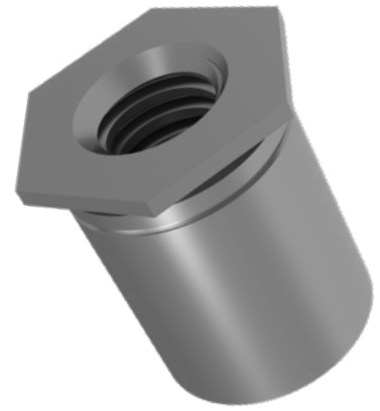

## AUSO™/AUSOS™/AUSOA™/AUSO4™ - THROUGH-HOLE THREADED STANDOFFS

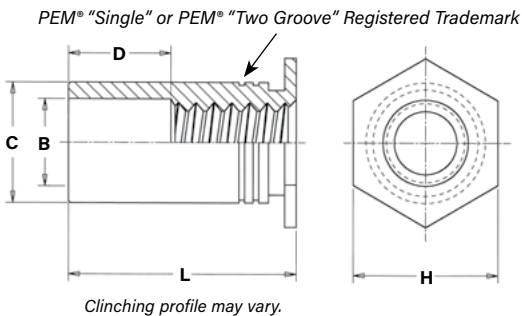

### PART NUMBER DESIGNATION

<b>AUSO</b>	-	<b>M4</b>	-	<b>18</b>		<b>ZI</b>	<b>C400</b>
<b>AUSOS</b>	-	<b>M4</b>	-	<b>18</b>			<b>C400</b>
<b>AUSOA</b>	-	<b>M4</b>	-	<b>18</b>			<b>C400</b>
<b>AUSO4</b>	-	<b>M4</b>	-	<b>18</b>		<b>NC*</b>	<b>C400</b>

↓	↓	↓	↓	↓
Type/ Material	Thread Size	Length	Finish	Clean Level

\* NC suffix is required if optional nickel plating (for corrosion resistance) is desired. Otherwise, no suffix is necessary.

## GENERAL DIMENSIONAL DATA

All dimensions are in millimeters.

METRIC	Thread Code	Min. Sheet Thickness	Hole Size In Sheet +0.08	B Counter-Bore Dia. ±0.13	C -0.13	H Nom.	Min. Dist. Hole $\varnothing$ To Edge	D ±0.25
	M3	1	4.22	3.2	4.2	4.8	6	Varies according to length. See length charts below.
	3.5M3	1	5.41	3.2	5.39	6.4	6.8	
	M3.5	1	5.41	3.9	5.39	6.4	6.8	
	M4	1.27	7.14	4.8	7.12	7.9	8	
M5	1.27	7.14	5.35	7.12	7.9	8		

Micro sizes also available.

See PEM® [Bulletin MPF](#) for more information.

## THREAD SIZE AND LENGTH SELECTION DATA

All dimensions are in millimeters.

METRIC	Thread Size x Pitch	Type				Thread Code	Length "L" +0.05 -0.13 (Length Code in millimeters)											
		Fastener Material					3	4	6	8	10	12	14	16	18	20	22	25
		Steel	Stainless Steel	Aluminum	Hardened Stainless Steel													
M3 x 0.5	AUSO	AUSOS	AUSOA	AUSO4	M3	3	4	6	8	10	12	14	16	18	-	-	-	
					3.5M3 <sup>(1)</sup>													
M3.5 x 0.6	AUSO	AUSOS	AUSOA	AUSO4	M3.5	3	4	6	8	10	12	14	16	18	20	22	25	
M4 x 0.7	AUSO	AUSOS	AUSOA	AUSO4	M4	3	4	6	8	10	12	14	16	18	20	22	25	
M5 x 0.8	AUSO	AUSOS	AUSOA	AUSO4	M5	3	4	6	8	10	12	14	16	18	20	22	25	
<b>D Dimension ±0.25</b>						None			4			8			11			

(1) Standoffs with thread code 3.5M3 have a thicker wall to provide more bearing surface for the mating component or panel reducing the chance of cracking or cutting into the board.

# SELF CLINCHING STANDOFFS

## AUBSO™/AUBSOS™/AUBSOA™/AUBSO4™ - BLIND THREADED STANDOFFS

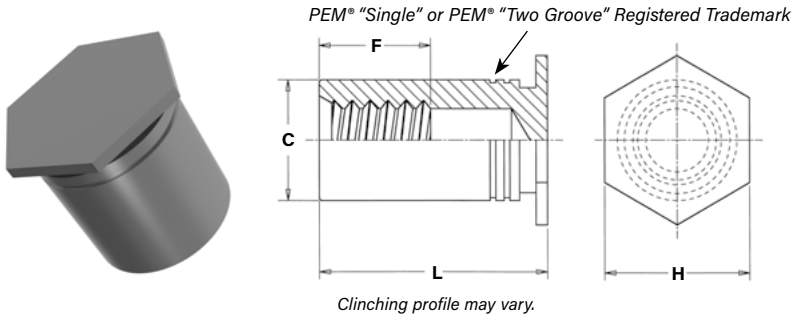

**PART NUMBER DESIGNATION**

<b>AUBSO</b>	-	<b>M4</b>	-	<b>18</b>	<b>ZI</b>	<b>C400</b>
<b>AUBSOS</b>	-	<b>M4</b>	-	<b>18</b>		<b>C400</b>
<b>AUBSOA</b>	-	<b>M4</b>	-	<b>18</b>		<b>C400</b>
<b>AUBSO4</b>	-	<b>M4</b>	-	<b>18</b>		<b>C400</b>

Type/  
Material      Thread  
Size      Length      Finish      Clean  
Level

### GENERAL DIMENSIONAL DATA

All dimensions are in millimeters.

	Thread Code	Min. Sheet Thickness	Hole Size In Sheet +0.08	C -0.13	H Nom.	Min. Dist. Hole $\varnothing$ To Edge	F Min.
<b>METRIC</b>	M3	1	4.22	4.2	4.8	6	Varies according to length. See length charts below.
	3.5M3	1	5.41	5.39	6.4	6.8	
	M3.5	1	5.41	5.39	6.4	6.8	
	M4	1.27	7.14	7.12	7.9	8	
	M5	1.27	7.14	7.12	7.9	8	

### THREAD SIZE AND LENGTH SELECTION DATA

All dimensions are in millimeters.

<b>METRIC</b>	Thread Size x Pitch	Type				Thread Code	Length "L" +0.05 -0.13 (Length Code in millimeters)									
		Steel	Stainless Steel	Aluminum	Hardened Stainless Steel											
	M3 x 0.5	AUBSO	AUBSOS	AUBSOA	AUBSO4	M3	6	8	10	12	14	16	18	20	22	25
					3.5M3 <sup>(1)</sup>											
M3.5 x 0.6	AUBSO	AUBSOS	AUBSOA	AUBSO4	M3.5	6	8	10	12	14	16	18	20	22	25	
M4 x 0.7	AUBSO	AUBSOS	AUBSOA	AUBSO4	M4	6	8	10	12	14	16	18	20	22	25	
M5 x 0.8	AUBSO	AUBSOS	AUBSOA	AUBSO4	M5	6	8	10	12	14	16	18	20	22	25	
<b>F Dimension Min.</b>						3.2	4	5	6.5	9.5						

(1) Standoffs with thread code 3.5M3 have a thicker wall to provide more bearing surface for the mating component or panel reducing the chance of cracking or cutting into the board.

# SELF CLINCHING STANDOFFS

## MATERIAL AND FINISH SPECIFICATIONS

Type	Threads <sup>(1)</sup>	Fastener Materials				Finishes			Clean Level <sup>(3)</sup>		For Use In Sheet Hardness: <sup>(4)</sup>			
	Internal, ASME B1.1, 2B ASME B1.13M, 6H	Hardened Carbon Steel	Aluminum	300 Series Stainless Steel	Hardened 400 Series Stainless Steel <sup>(5)</sup>	Zinc Plated per ASTM, B633, SC1 (5µm) Type III, Colorless <sup>(2)</sup>	Passivated and/or Tested Per ASTM A380	Zinc Nickel Plated per ISO 19598 Fe//ZnNi8//Cu//TO 720h to red rust per ISO 9227 Salt Spray Test <sup>(2)</sup>	Max. Metallic Particle Size 400µm	Max. Metallic Particle Size 600µm	HRB 88/ HB 183 or Less	HRB 80/ HB 150 or Less	HRB 70/ HB 125 or Less	HRB 50/ HB 89 or Less
AUSO	■	■				■		■	■					
AUSOA	■		■						■	■				■
AUSOS	■			■			■		■	■			■	
AUSO4	■				■		■		■	■	■			
AUBSO	■	■				■		■	■	■	■			
AUBSOA	■		■						■	■				■
AUBSOS	■			■			■		■	■			■	
AUBSO4	■				■		■		■	■	■			
Part Number Codes For Finishes						ZI	None	ZN	C400	C600				

- (1) Where applicable.
- (2) See PEM® Technical Support section of our website for related plating standards and specifications.
- (3) Parts requiring technical cleanliness will be considered a custom fastening solution. If technical cleanliness is not required on your part, do not include a clean level number when ordering.
- (4) HRB - Hardness Rockwell "B" Scale. HB - Hardness Brinell.
- (5) In order for self clinching fasteners to work properly, the fastener must be harder than the sheet into which it is being installed (For more information, see our [tech sheet](#) for installing fasteners into stainless steel sheets). In the case of stainless steel panels, fasteners made from 300 Series Stainless Steel do not meet this hardness criteria. It is for this reason that AUSO4™ and AUBSO4™ 400 series fasteners are offered. However, while these 400 Series fasteners install and perform well in 300 Series stainless sheets they should not be used if the end product will be exposed to any appreciable corrosive environment (unless finished with optional nickel plating), requires non-magnetic fasteners or will be exposed to any temperatures above 300 °F (149 °C). If any of the these are issues, please contact [techsupport@pemnet.com](mailto:techsupport@pemnet.com) for other options.

## INSTALLATION

### AUSO™/AUSOS™/AUSOA™/AUSO4™/AUBSO™/AUBSOS™/AUBSOA™/AUBSO4™ STANDOFFS

1. Prepare properly sized mounting hole in sheet. Do not perform any secondary operation such as deburring.
2. Insert standoff through mounting hole (preferably the punch side) of sheet and into anvil as shown in drawing.
3. With installation punch and anvil surfaces parallel, apply only enough squeezing force to embed the standoff's head flush in the sheet. Drawing at right shows suggested tooling for applying these forces.

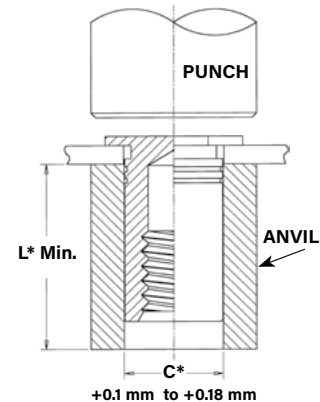

### PEMSERTER® Installation Tooling

Thread Code	Anvil Part Number	Punch Part Number
M2/M2.5/M3	970200487300	975200048
3.5M3/M3.5	970200012300	
M4	970200013300	
M5	970200013300	
M6	970200393300	

# SELF CLINCHING STANDOFFS

## PERFORMANCE DATA

### AUSO™/AUSOS™/AUSOA™/AUBSO™/AUBSOS™/AUBSOA™ STANDOFFS

METRIC	Thread Code	Standoff Material	Max. Rec. Tightening Torque For Mating Screw (N-m)	Test Sheet Material (2)							
				1.5 mm 5052-H34 Aluminum				1.5 mm Cold-rolled Steel			
				Installation (kN)	Pushout (N)	Torque-out (3) (N-m)	Pull-thru (3) (N)	Installation (kN)	Pushout (N)	Torque-out (3) (N-m)	Pull-thru (3) (N)
	M3	Steel	0.55	4.9	710	1.24	1245	9.8	1000	2.15	1465
		Stainless Steel	0.44	4.9	710	1.24	996	9.8	1000	2.15	1172
		Aluminum	0.33	4.9	710	1.24	747	-	-	-	-
	3.5M3	Steel	0.55	7.6	1330	2.82	1375	14.7	1860	3.95	1690
		Stainless Steel	0.44	7.6	1330	2.82	1100	14.7	1860	3.95	1352
		Aluminum	0.33	7.6	1330	2.82	825	-	-	-	-
	M3.5	Steel	0.91	7.6	1330	2.82	1375	14.7	1860	3.95	1690
		Stainless Steel	0.73	7.6	1330	2.82	1100	14.7	1860	3.95	1352
		Aluminum	0.55	7.6	1330	2.82	825	-	-	-	-
M4	Steel	2	10.7	1780	5.08	2575	17.8	2490	8.47	3110	
	Stainless Steel	1.6	10.7	1780	5.08	2060	17.8	2490	8.47	2488	
	Aluminum	1.2	10.7	1780	5.08	1545	-	-	-	-	
M5	Steel	3.6	10.7	1780	5.08	2575	17.8	2490	8.47	3110	
	Stainless Steel	2.88	10.7	1780	5.08	2060	17.8	2490	8.47	2488	
	Aluminum	2.16	10.7	1780	5.08	1545	-	-	-	-	

### AUSO4™/AUBSO4™ STANDOFFS

METRIC	Thread Code	Max. Rec. Tightening Torque For Mating Screw (N-m)	Test Sheet Material			
			1.3 mm 300 Series Stainless Steel			
			Installation (kN)	Pushout (N)	Torque-out (3) (N-m)	Pull-thru (3) (N)
	M3	0.55	24.5	1493	2.36	2650
	3.5M3	0.55	42.3	2877	3.06	3025
	M3.5	0.91	42.3	2877	3.06	3025
	M4	2	46.7	4003	8.89	6458
	M5	3.6	46.7	4003	8.89	6226

- (1) Published installation forces are for general reference. Actual set-up and confirmation of complete installation should be made by observing proper seating of fastener as described in the installation steps. Other performance values reported are averages when all proper installation parameters and procedures are followed. Variations in mounting hole size, sheet material, and installation procedure may affect performance. Performance testing this product in your application is recommended. We will be happy to provide technical assistance and/or samples for this purpose.
- (2) See [tech sheet](#) on our website for performance data of PEM® Type AUSO™ standoffs installed into copper sheets.
- (3) Joint failure in torque-out and pull-thru will depend on the strength and type of screw being used. In some cases the failure will be in the screw and not in the self clinching standoff. Please contact our Applications Engineering group with any questions.

## FASTENERS FOR USE WITH PC BOARDS

No matter how sophisticated or advanced, electronic components must be attached reliably and securely if they are to deliver optimum performance. We offer several fastener products for use with PC boards to satisfy component-to-board, board-to-board, and board-to-chassis attachment needs.



**ReelFast® Surface Mount Fasteners** mount on PC boards in the same manner and at the same time as other surface mount components prior to the automated reflow solder process. The fasteners simply become another board component. This alleviates concerns about potential damage to PC boards due to improper secondary installation operations. The fasteners are provided on tape and reel compatible with existing SMT automated installation equipment. The benefits of using ReelFast® SMT fasteners are: faster assembly; reduced scrap; reduced handling; and reduced risk of board damage.

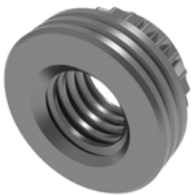

**Broaching Fasteners** can also offer practical alternatives to “loose” hardware. A broaching fastener is a knurled-shank fastening device that can be pressed into a hole to provide a permanent, strong, threaded or unthreaded attachment point in PC boards. They can also be used in aluminum, acrylic, casting and polycarbonate components. Specially formed axial grooves around the shank of the fastener “broach” or cut into the material, creating a firm, interference-type fit resistant to rotation. In PC boards, broaching fasteners are recommended for use in non-plated holes.



**Broach/Flare-mount Standoffs (AUKFB3™)** offer a combined broach/flare feature for even greater pullout performance in PC board materials.

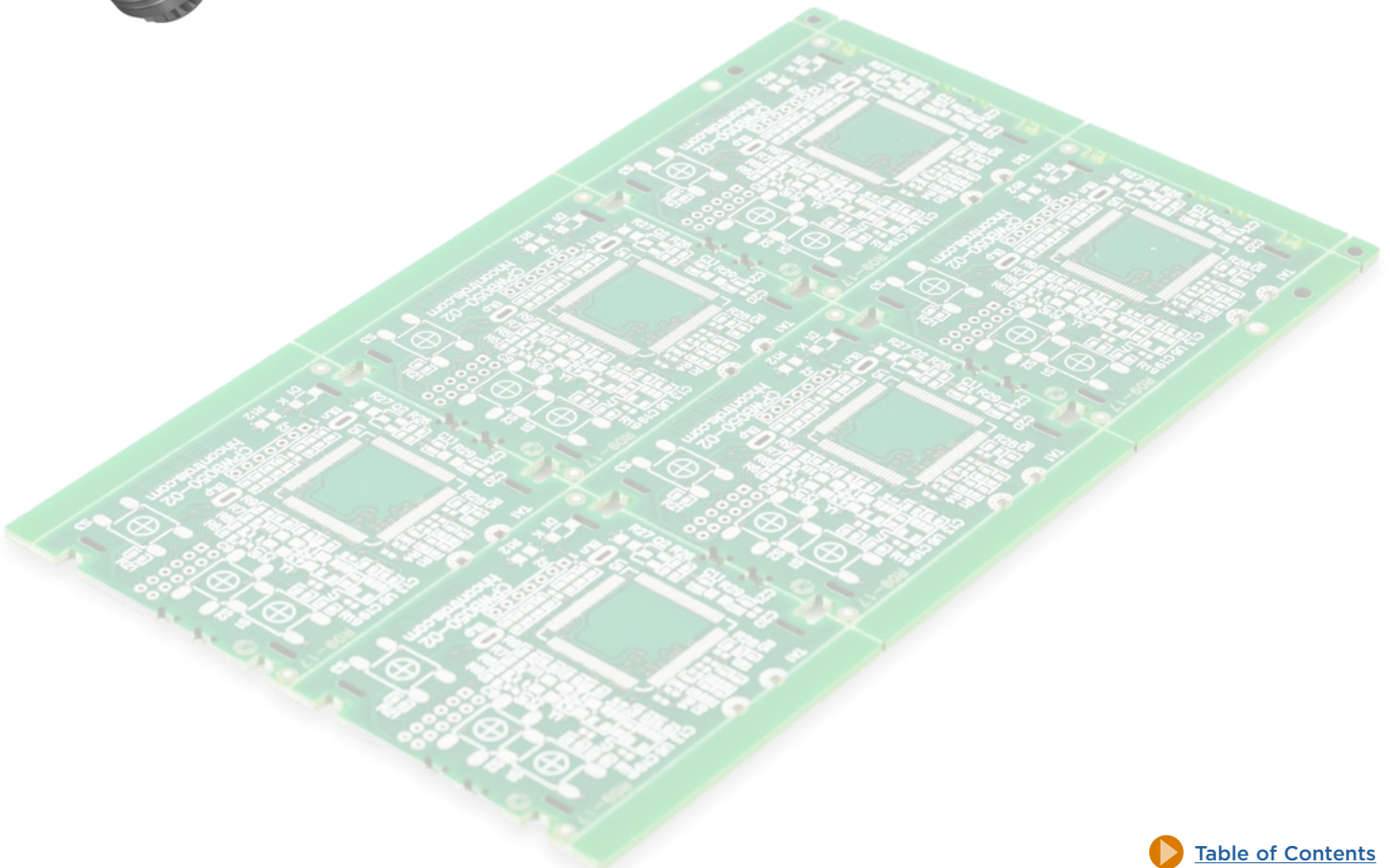

# FASTENERS FOR USE WITH PC BOARDS

## AUSMSTO™/AUSMSTOB™ REELFAST® SURFACE MOUNT NUTS AND SPACERS/STANDOFFS

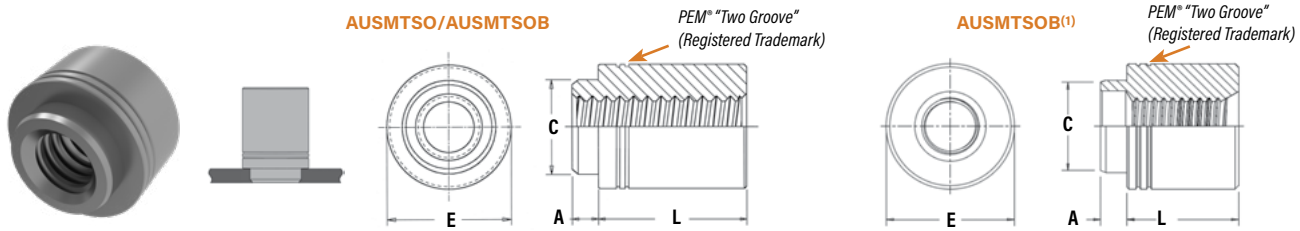

Thread/thru hole sizes M2, M2.5, M3, M3.5, M4, 3.1, 3.6, and 4.2

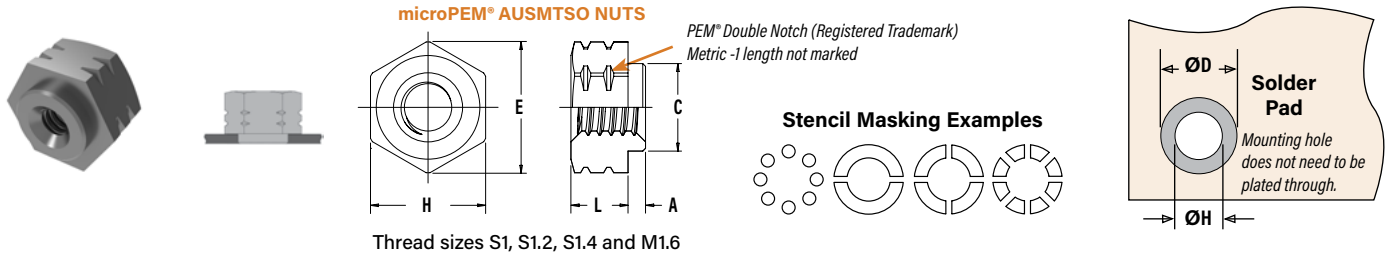

Thread sizes S1, S1.2, S1.4 and M1.6

### PART NUMBER DESIGNATION

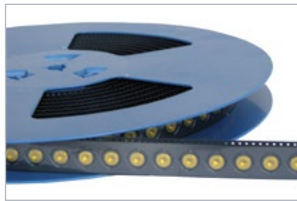
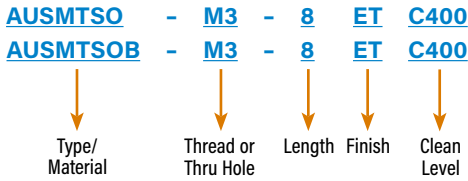

Packaged on 330 mm recyclable reels. Tape width is 24 mm. Reels conform to EIA-481.

A polyimide patch is supplied to allow for reliable vacuum pickup. Fasteners are also available without a patch which may provide a lower cost alternative, depending on your installation methods/requirements.

All dimensions are in millimeters.

METRIC	Thread Size x Pitch	Thru Hole +0.10 -0.08	Type		Thread or Thru Hole Code	Length Code "L" ±0.13 (Length code in millimeters)						Min. Sheet Thickness	A Max.	C Max.	E		H Nom.	ØH Hole Size In Sheet +0.08	ØD Min. Solder Pad	
			Fastener Material			1	2	3	4	6	8				10	Ref.				±0.13
			Steel	Brass																
	S1	—	AUSMSTO	—	M1	1	2	3	—	—	—	0.5	0.48	2.41	3.66	—	3.18	2.5	4.19	
	S1.2	—	AUSMSTO	—	M1.2	1	2	3	—	—	—	0.5	0.48	2.41	3.66	—	3.18	2.5	4.19	
	S1.4	—	AUSMSTO	—	M1.4	1	2	3	—	—	—	0.5	0.48	2.41	3.66	—	3.18	2.5	4.19	
	M1.6 x 0.35	—	AUSMSTO	—	M1.6	1	2	3	—	—	—	0.5	0.48	2.41	3.66	—	3.18	2.5	4.19	
	M2 x 0.4	—	AUSMSTO	AUSMSTOB	M2	—	2	3	4 <sup>(1)</sup>	6 <sup>(1)</sup>	8 <sup>(1)</sup>	10 <sup>(1)</sup>	1.53	1.53	3.6	—	5.56	—	3.73	6.2
	M2.5 x 0.45	—	AUSMSTO	AUSMSTOB	M25	—	2	3	4 <sup>(1)</sup>	6 <sup>(1)</sup>	8 <sup>(1)</sup>	10 <sup>(1)</sup>	1.53	1.53	4.09	—	5.56	—	4.22	6.2
	M3 x 0.5	—	AUSMSTO	AUSMSTOB	M3	—	2	3	4 <sup>(1)</sup>	6 <sup>(1)</sup>	8 <sup>(1)</sup>	10 <sup>(1)</sup>	1.53	1.53	4.09	—	5.56	—	4.22	6.2
	M3.5 x 0.6	—	AUSMSTO	AUSMSTOB	M35	—	2	3	4 <sup>(1)</sup>	6 <sup>(1)</sup>	8 <sup>(1)</sup>	10 <sup>(1)</sup>	1.53	1.53	5.28	—	7.14	—	5.41	7.77
	M4 x 0.7	—	AUSMSTO	AUSMSTOB	M4	—	2	3	4	6 <sup>(1)</sup>	8 <sup>(1)</sup>	10 <sup>(1)</sup>	1.53	1.53	6.22	—	8.74	—	6.35	9.37
	—	3.1	AUSMSTO	AUSMSTOB	3.1	—	2	3	4	6	8	10	1.53	1.53	4.09	—	5.56	—	4.22	6.2
	—	3.6	AUSMSTO	AUSMSTOB	3.6	—	2	3	4	6	8	10	1.53	1.53	5.28	—	7.14	—	5.41	7.77
	—	4.2	AUSMSTO	AUSMSTOB	4.2	—	2	3	4	6	8	10	1.53	1.53	6.22	—	8.74	—	6.35	9.37

(1) AUSMSTOB fasteners with this length code have a shank counterbore.

### NUMBER OF PARTS PER REEL / PITCH (MM) FOR EACH SIZE

Thread/Thru-Hole Size	Length Code							
	1	2	3	4	6	8	10	12
M1, M1.2, M1.4, M1.6	3500 / 8	2500 / 8	2000 / 8	—	—	—	—	—
M2, M25, M3, M35, 3.1, 3.6	—	1500 / 12	1000 / 12	900 / 12	650 / 12	375 / 16	300 / 16	—
M4, 4.2	—	1100 / 16	800 / 16	675 / 16	500 / 16	375 / 16	300 / 16	—

**NOTE:** Standoffs are available on special order without a pilot that do not require a thru hole for installation. Contact [techsupport@pemnet.com](mailto:techsupport@pemnet.com) for more information.



# FASTENERS FOR USE WITH PC BOARDS

## AUKFB3™ BROACH/FLARE-MOUNT STANDOFFS

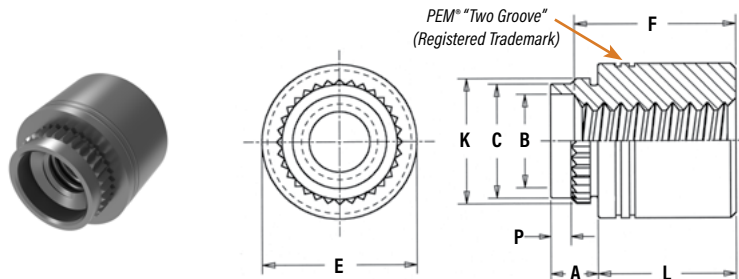

### PART NUMBER DESIGNATION

**AUKFB3 - M3 - 12 ET C400**

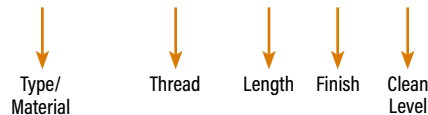

All dimensions are in millimeters.

METRIC	Thread Size x Pitch	Type	Thread Code	Length "L" ±0.13 (Length Code is in millimeters)								A (Shank) Max.	Sheet Thickness	Hole Size in Sheet +0.13 -0.03	B ±0.08	C Max.	E ±0.13	K ±0.08	P ±0.25	Min. Dist. Hole To Edge	
	M3 x 0.5	AUKFB3	M3	2	3	4	6	8	10	12	14	16	2.29	1.27-1.65	4.22	3.23	4.2	5.56	4.55	1	4.33
	M4 x 0.7	AUKFB3	M4	2	3	4	6	8	10	12	14	16	2.29	1.27-1.65	6.4	5.23	6.33	8.74	6.68	1	6.36
"F" Min. Thread Length (Where Applicable)				Full								9.5 ±0.4									

## MATERIAL AND FINISH SPECIFICATIONS

Type	Threads (1)		Fastener Materials			Finishes (2)		Clean Level (3)		For Use in Sheet Hardness: (4)				
	Miniature ISO 1501, 4H6	Internal, ASME B1.1 2B/ ASME B1.13M 6H	Lead-free Carbon Steel	300 Series Stainless Steel	Brass	Passivated and/or Tested per ASTM A380	Electro-Plated Tin ASTM B 545, Class B with Clear Preservative Coating, annealed (5)	Max. Metallic Particle Size 400µm	Max. Metallic Particle Size 600µm	HRB 70 / HB 125 or Less	HRB 65 / HB 116 or Less	HRB 60 / HB 107 or Less	Aluminum, Acrylic Castings, Polycarbonate, and PC board	PC Board
AUKF2		▪	▪				▪	▪				▪	▪	
AUKFS2		▪		▪		▪		▪	▪	▪			▪	
AUKFE		▪	▪				▪	▪				▪	▪	
AUKFSE		▪		▪		▪		▪	▪	▪			▪	
AUKFB3		▪			▪		▪	▪			▪		▪	
AUSMSTSO	▪ S1 to S1.4	▪ 0-80 to 8-32/ M1.6 to M4	▪				▪	▪						▪
AUSMSTSOB		▪			▪	(6)	▪	▪						▪
Part Number Codes For Finishes						None	ET	C400	C600					

- (1) For plated studs, Class 2A/6g, the maximum major and pitch diameter, after plating, may equal basic sizes and can be gauged to Class 3A/6h, per ASME B1.1 Section 7, Paragraph 2 and ASME B1.13M, Section 8, Paragraph 8.2.
- (2) See PEM® Technical Support section of our web site for related plating standards and specifications.
- (3) Parts requiring technical cleanliness will be considered a custom fastening solution. If technical cleanliness is not required on your part, do not include a clean level number when ordering.
- (4) HRB - Hardness Rockwell "B" Scale. HB - Hardness Brinell.
- (5) Optimal solderability life noted on packaging.
- (6) The tin deposit on type AUSMSTSOB meets the requirements of ASTM B545, Class A and although the copper and nickel barrier layers used under the tin do not strictly comply with ASTM B545 thickness requirements they have proven effective at preventing zinc migration and providing the specified solderable shelf life.

# FASTENERS FOR USE WITH PC BOARDS

## INSTALLATIONS

### AUKF2™/AUKFS2™/AUKFE™/AUKFSE™ FASTENERS

1. Prepare properly sized mounting hole in board.
2. Place fastener into the anvil hole and place the mounting hole over the shank of the fastener as shown in drawing.
3. With installation punch and anvil surfaces parallel, apply squeezing force until shoulder contacts the board.

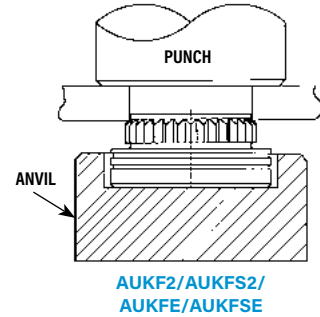

### PEMSERTER® Installation Tooling

Type	Thread Code	Anvil Part Number	Punch Part Number
AUKFE/AUKFSE	M3 -3 to -6	975200846300	
AUKFE/AUKFSE	M3 -8 to -10	975200847300	
AUKFE/AUKFSE	M3 -12 to -14	975201222300	
AUKFE/AUKFSE	M3 -14 to -16	975200848300	
AUKFE/AUKFSE	3.6 -3 to -6	975200849300	
AUKFE/AUKFSE	3.6 -8 to -10	975200850300	975200048
AUKFE/AUKFSE	3.6 -12 to -16	975200851300	
AUKFE/AUKFSE	4.2 -2	975201216300	
AUKFE/AUKFSE	4.2 -3 to -6	975201217300	
AUKFE/AUKFSE	4.2 -8 to -10	975201218300	
AUKFE/AUKFSE	4.2 -12 to -14	975201220300	
AUKFE/AUKFSE	4.2 -14 to -16	975201219300	

Type	Thread Code	Anvil Part Number	Punch Part Number
KF2/KFS2	M2/M2.5/M3	975200904300	975200048
KF2/KFS2	M3.5	975200035	
KF2/KFS2	M4	975200037	
KF2/KFS2	M5	975200905300	

### AUKFB3™ FASTENERS

1. Prepare properly sized mounting hole in board.
2. Place fastener into the anvil hole and place the mounting hole over the shank of the fastener as shown in diagram to the left.
3. Using a punch flaring tool and a recessed anvil, apply squeezing force until the shoulder of the fastener contacts the board. As the fastener seats itself in the proper position, the punch tool will flare the extended portion of the shank outward to complete the installation. The combination of broaching and flaring provides high pushout performance.

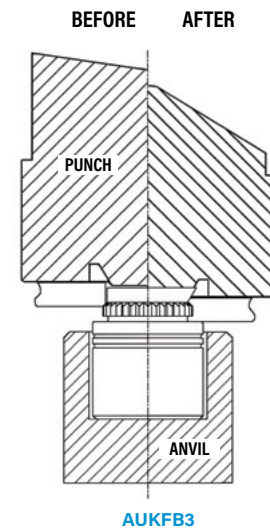

### PEMSERTER® Installation Tooling

Thread Code	Length Code	Anvil	Punch (Flaring Tool)
M3	-2	975201213300	975201231400
M3	-3 to -6	975200846300	
M3	-8 to -10	975200847300	
M3	-12 to -14	975201222300	
M3	-14 to -16	975200848300	
M4	-2	975201216300	975201221400
M4	-3 to -6	975201217300	
M4	-8 to -10	975201218300	
M4	-12 to -14	975201220300	
M4	-14 to -16	975201219300	

(1) PennEngineering® manufactures and stocks the installation tooling for AUKFB3 fasteners.

# FASTENERS FOR USE WITH PC BOARDS

## INSTALLATIONS

### AUSMTSO™ NUTS AND STANDOFFS

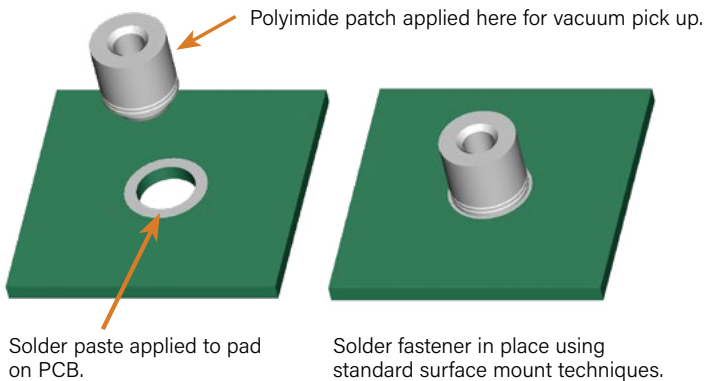

## PERFORMANCE DATA<sup>(1)</sup>

### AUKF2™/AUKFS2™/AUKFE™/AUKFSE™/AUKFB3™ FASTENERS

METRIC	Type	Thread Code	Max. Nut Tightening Torque (N-m)	Test Sheet Thickness & Test Sheet Material	Installation (kN)	Pushout <sup>(2)</sup> (N)	Torque-out (N-m)
	AUKF2, AUKFS2	M2	(3)	1.5 mm FR-4 Panel	2.2	267	0.68
		M3	(3)	1.5 mm FR-4 Panel	2.2	290	1.7
		M4	(3)	1.5 mm FR-4 Panel	2.2	420	3.4
		M5	(3)	1.5 mm FR-4 Panel	2.9	440	4.5
	AUKFB3	M3	(3)	1.5 mm FR-4 Panel	4.4	560	2.03
		M4	(3)	1.5 mm FR-4 Panel	6	680	3.2
	AUKFH	M3	0.45	1.5 mm FR-4 Panel	1.8	285	0.79
		M4	1.6	1.5 mm FR-4 Panel	1.8	355	1.8
		M5	2.1	1.5 mm FR-4 Panel	1.8	400	1.92
AUPFK	M3	(3)	1.5 mm FR-4 Panel	1.1	245	(3)	

### AUSMTSO™/AUSMTOB™ FASTENERS<sup>(1)(2)</sup>

Type	Thread/ Thru-hole Code	Test Sheet Material - .062" Single Layer FR-4		Rated Current Amps <sup>(3)</sup>
		Pushout (N)	Torque-out (N-m)	
AUSMTSO	M1	378.7	0.56	11
AUSMTOB				—
AUSMTSO	M1.2	378.7	0.56	10
AUSMTOB				—
AUSMTSO	M1.4	378.7	0.56	10
AUSMTOB				—
AUSMTSO	M1.6	378.7	0.56	10
AUSMTOB				—
AUSMTSO	M3	251	1	22
AUSMTOB				36
AUSMTSO	M3.5	416	1.6	34
AUSMTOB				55
AUSMTSO	M4	672	3	47
AUSMTOB				76
AUSMTSO	3.1	—	—	22
AUSMTOB				36
AUSMTSO	3.6	—	—	33
AUSMTOB				55
AUSMTSO	4.2	—	—	46
AUSMTOB				75

- (1) With lead-free paste. Average values of 30 test points. The data presented here is for general comparison purposes only. Actual performance is dependent upon application variables. We will be happy to provide samples for you to install. If required, we can also test your installed hardware and provide you with the performance data specific to your application.
- (2) Further testing details can be found in our website's literature section.
- (3) The maximum carrying current for each of the above fasteners is calculated based on a heat transfer coefficient of 20 W/m<sup>2</sup> °K and a maximum temperature rise of 15°C / 27°F above ambient.

# FASTENERS FOR USE WITH PC BOARDS

## AUSMTO™/AUSMTOB™ FASTENERS(1)(2)

### Testing Conditions for Surface Mounted Fasteners

**Oven:** Quad ZCR convection oven w/ 4 zones  
**High Temp:** 473°F / 245°C  
**Board Finish:** 62% Sn, 38% Pb  
**Screen Printer:** Ragin Manual Printer  
**Vias:** None

**Spokes:** 2 Spoke Pattern  
**Paste:** Amtech NC559LF Sn96.5/3.0Ag/0.5Cu  
(AUSAC305) (AUSMTO, AUSMTRA, AUSMTPR)  
Alpha CVP-390 Sn96.5/3.0Ag/0.5Cu  
(AUSAC305) (AUSMTPFLSM, AUSMTSS, AUSMTSK)  
**Stencil:** .0067" / 0.17 mm thick  
(AUSMTO, AUSMTRA, AUSMTPR, AUSMTSS, AUSMTSK)  
.005" / 0.13 mm thick (AUSMTPFLSM)

### AUSMTO™ REFLOW CURVE

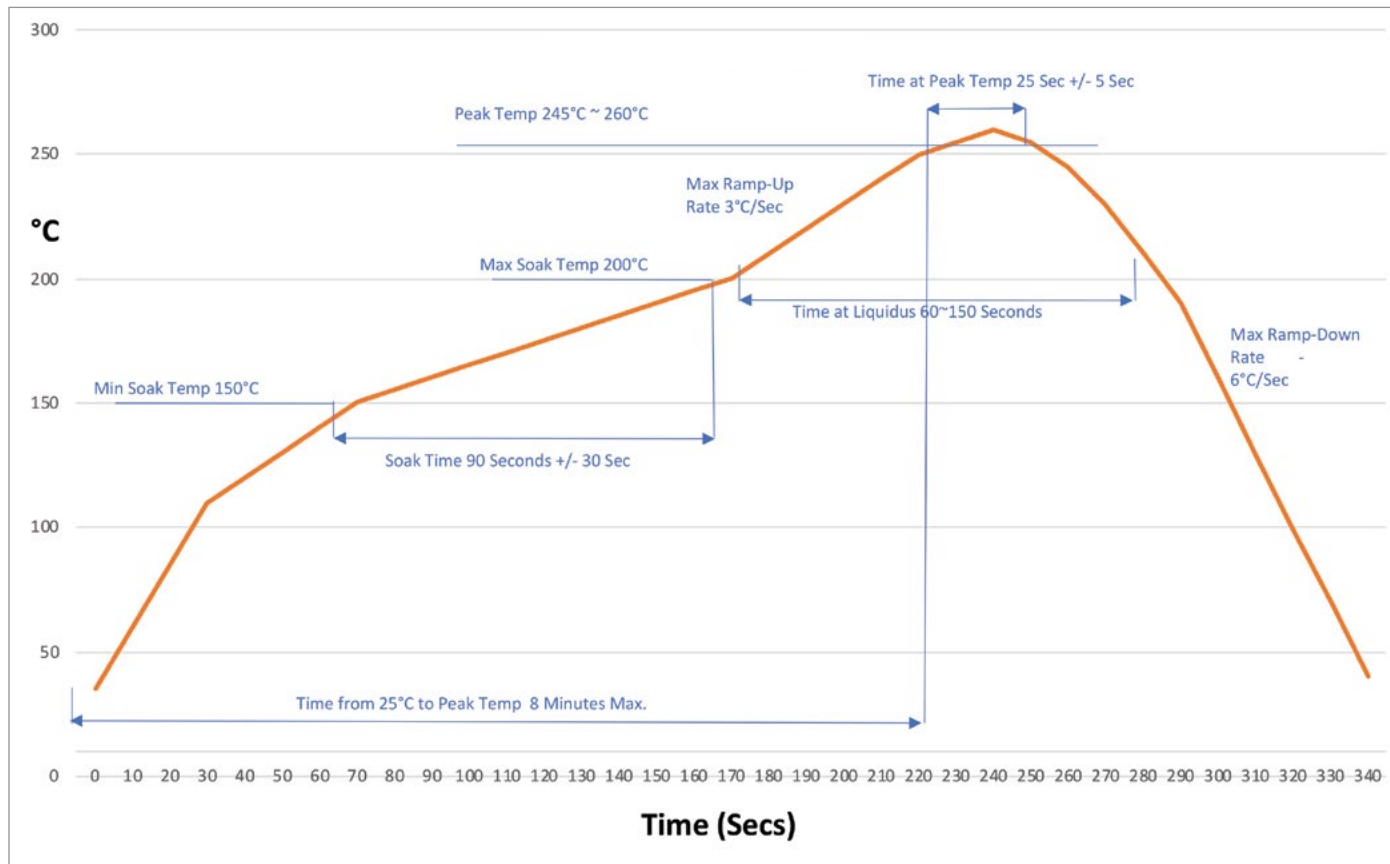



# SPINNING FLARE NUT

## INSTALLATIONS

1. Prepare properly sized embossed mounting hole in sheet. Do not perform any secondary operations such as deburring.
2. Insert fastener into the recessed anvil and place the mounting hole (preferably the punch side) over the shank of the fastener.
3. With installation punch and anvil surfaces parallel, apply squeezing force to flare the shank of the fastener.

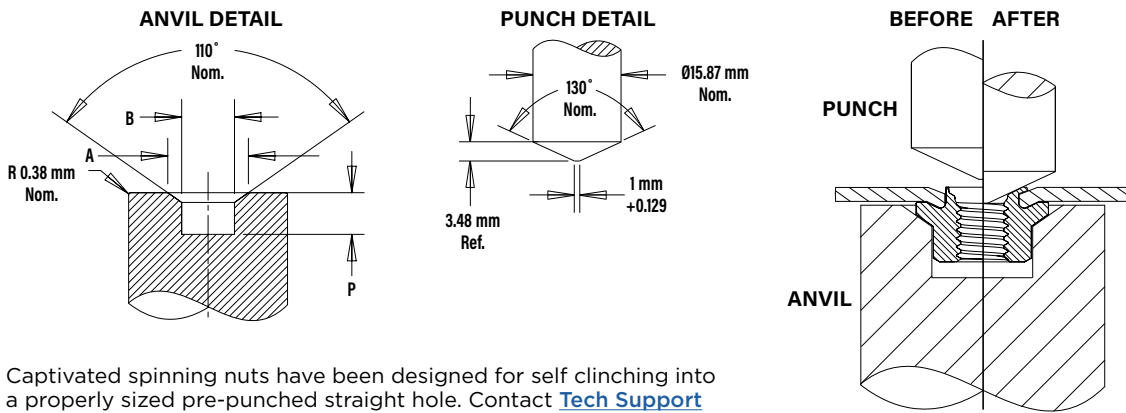

Captivated spinning nuts have been designed for self clinching into a properly sized pre-punched straight hole. Contact [Tech Support](#) for more information

## PEMSERTER® Installation Tooling

Type	Thread Code	Anvil Dimensions (mm)			Flaring Anvil Part Number	Punch Part Number
		A ±0.127	B ±0.025	P Min.		
AUSFN	M5	14.5	9.5	7.49	8018538	8018670
AUSFN	M6	19	11.81	8.51	8018539	8018670
AUSFN	M8	22.61	15.29	10.49	8018540	8018670

If your application requires installation into a flat sheet, please contact our technical support at [techsupport@pemnet.com](mailto:techsupport@pemnet.com) as we have tooling options available.

## PERFORMANCE DATA<sup>(1)</sup>

METRIC	Type	Thread Code	Shank Code	Test Sheet Material					
				Stainless Steel		Cold-rolled Steel		Aluminum	
				Installation (kN)	Pushout (N)	Installation (kN)	Pushout (N)	Installation (kN)	Pushout (N)
AUSFN	M5		1	7.2	862	7.2	642	5.8	428
			2	7.2	1261	7.2	1261	5.8	1261
AUSFN	M6		00	12.9	964	12.9	642	12.9	428
			1	12.9	1431	12.9	1431	12.9	1329
AUSFN	M8		00	12.9	964	12.9	642	12.9	642
			1	12.9	1431	12.9	1431	12.9	1329

(1) Published installation forces are for general reference. Actual set-up and confirmation of complete installation should be made by observing proper seating of fastener as described in the installation steps. Other performance values reported are averages when all proper installation parameters and procedures are followed. Variations in mounting hole size, sheet material, and installation procedure may affect performance. Performance testing this product in your application is recommended. We will be happy to provide technical assistance and/or samples for this purpose.

## Table of Contents

Click links below for shortcuts to information.

- [PEM® / SI® Innovation](#)
- [Automotive Electronics Applications:](#)
  - [Powertrain](#)
  - [Infotainment](#)
  - [Safety & ADAS](#)
  - [Body Electronics](#)
- [PEM® Fasteners:](#)
  - [AUB™ Nut](#)
  - [AUS™ Nut](#)
  - [AUFH™ Studs](#)
  - [AUHFH™ Studs](#)
  - [AUHFE™ Studs](#)
  - [AUTHFE™ Studs](#)
  - [AUSO™ Standoff](#)
  - [AUBSO™ Standoff](#)
  - [AUSMT™](#)
  - [AUKF2™](#)
  - [AUKFE™](#)
  - [AUKFB3™](#)
  - [AUSFN™](#)
- [SI® Fasteners](#)
  - [Flanged Head Compression Limiters](#)
  - [Symmetrical Compression Limiters](#)
  - [Full Diamond Knurl Compression Limiters](#)
  - [Non-Knurled Symmetrical Compression Limiters](#)
  - [Ultrasonic/Heat Staking Inserts](#)
  - [Blind Threaded Molded-in Inserts](#)
  - [Thru-threaded, Knurled Molded-in Inserts](#)
  - [Hexagonal Press-in Inserts](#)

## SI® FASTENERS

SI® inserts are typically specified in applications where strong, reusable, permanent threads are required in plastic materials, especially when frequent assembly and disassembly of the unit is required.

### COMPRESSION LIMITERS

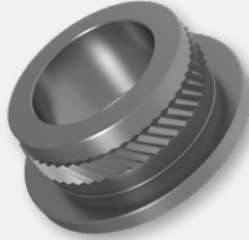

[Flange-Head](#)



[Symmetrical](#)

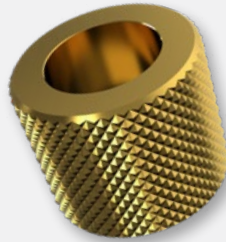

[Full Diamond Knurl](#)



[Non-knurled Symmetrical](#)

### INSERTS FOR PLASTIC

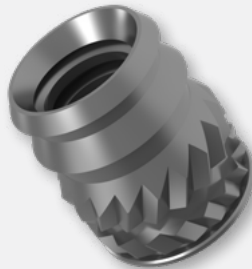

[Ultrasonic / Heat Staking Inserts](#)

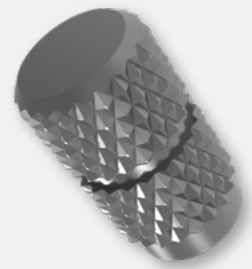

[Blind Threaded Molded-in Inserts](#)

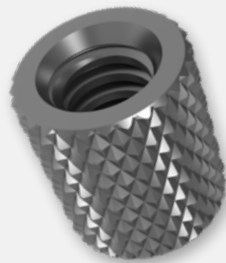

[Thru-threaded, Knurled Molded-in Inserts](#)

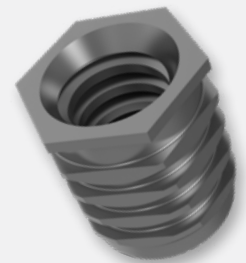

[Hexagonal Press-in Inserts](#)

# COMPRESSION LIMITERS FOR PLASTIC APPLICATIONS

SI® Compression limiters are non-threaded inserts that are commonly used in applications where a compressive load is applied to a plastic assembly. The compression limiter strengthens the plastic and withstands the compressive force that is applied when a mating screw is tightened in the assembly. The integrity of the plastic is not compromised by the load that is applied.

- Custom designed in a wide range of sizes and profiles
- Available in brass, stainless steel, and lead-free aluminum
- Installed using ultrasonic, heat-staking or molded-in installation methods
- Available design types; flange-head, symmetrical, full diamond knurl and non-knurled symmetrical

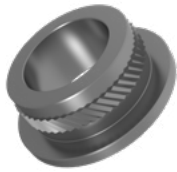

### Flange-head

Larger contact area provides high resistance to axial loads and eliminates direct contact of plastic with mating components. Can be used for all installation methods.



### Symmetrical

Symmetrical design offers fast loading without the need to orientate the part. Can be used for all installation methods.

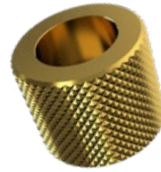

### Full Diamond Knurl

Symmetrical design and uniform diamond knurl reduces the risk of sink marks. Can be used in mold-in installation.



### Non-knurled Symmetrical

Symmetrical design with retention groove for use in automation and high-volume applications needing compressive load resistance. Can be used in mold-in installation.

## AVAILABLE OPTIONS

Installation Methods	Insert Design Types	Insert Materials	Finishes	Clearance Hole for Mating Screw Sizes:
Ultrasonic Heat Staking Molded-in	Flange-head Symmetrical Full Diamond Knurl Non-knurled Symmetrical	Aluminum, Brass	Plain	#2-56 through 5/16-18 and M2 through M8
		Carbon Steel	Zinc plated, 5µm, colorless	
		Stainless Steel	Passivated and/or tested per ASTM A380	

## SAMPLING OF INSERT DESIGN TYPES

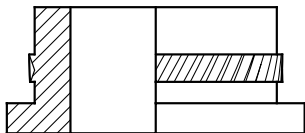

Flange-head

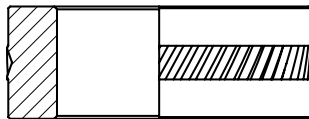

Symmetrical

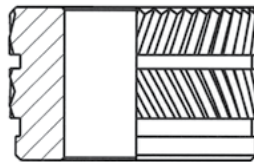

Straight Wall Knurled

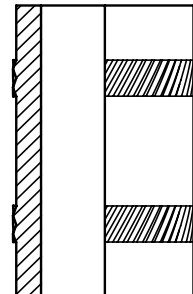

Symmetrical

# ULTRASONIC / HEAT STAKING INSERTS

## Tapered Thru-Threaded, AUIUA™, AUIUB™ and AUIUC™ Inserts

- Designed for use in tapered holes.
- Tapered mounting hole allows for rapid and accurate alignment prior to installation.
- Aluminum inserts ideal for light weight designs.
- Aluminum and stainless steel inserts offer lead-free alternative.

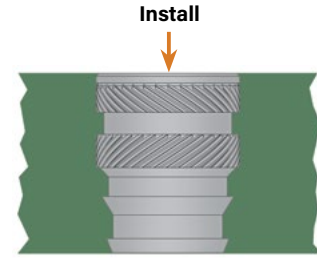
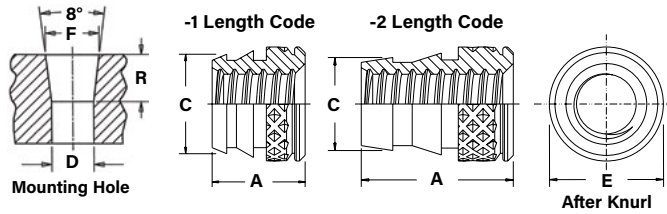
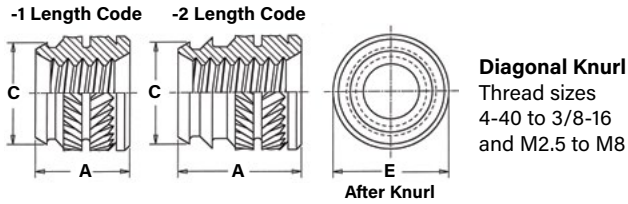

All dimensions are in millimeters.

METRIC	Thread Size x Pitch	Type			Thread Code (1)	Length Code	A ± 0.13	E ± 0.13	C ± 0.13	Hole Size in Material			
		Aluminum	Brass	Stainless Steel						Min. Hole Depth	D ± 0.05	F ± 0.05	R Ref. Taper Length
M2 x 0.4	AUIUA	AUIUB	AUIUC	M2	1	2.92	3.58	3.12	3.94	3	3.12	0.9	
					2	3.43	4.37	3.99	4.44	3.89	1.07		
M2.5 x 0.45	AUIUA	AUIUB	AUIUC	M2.5	1	3.43	4.37	3.99	4.44	3.89	4.04	1.07	
					2	5.56	3.79	6.58	3.58	3.29			
M3 x 0.5	AUIUA	AUIUB	AUIUC	M3	1	3.43	4.37	3.99	4.44	3.89	4.04	1.07	
					2	5.56	3.79	6.58	3.58	3.29			
M3 x 0.5	AUIUAA	AUIUBB	AUIUCC	M3	1	3.81	5.56	5.16	4.83	5.05	5.23	1.29	
					2	6.35	4.83	7.42	4.7	3.79			
M3.5 x 0.6	AUIUA	AUIUB	AUIUC	M3.5	1	3.81	5.56	5.16	4.83	5.05	5.23	1.29	
					2	6.35	4.83	7.42	4.7	3.79			
M4 x 0.7	AUIUA	AUIUB	AUIUC	M4	1	4.7	6.35	5.84	5.72	5.74	5.94	1.43	
					2	7.92	5.41	8.94	5.28	4.72			
M5 x 0.8	AUIUA	AUIUB	AUIUC	M5	1	5.72	7.54	6.91	6.74	6.78	7.03	1.79	
					2	9.53	6.38	10.55	6.25	5.58			
M5 x 0.8	AUIUAA	AUIUBB	AUIUCC	M5	1	6.71	8.33	7.83	7.72	7.7	8	2.15	
					2	11.1	7.16	12.12	7.06	6.72			
M6 x 1	AUIUA	AUIUB	AUIUC	M6	1	7.62	9.52	8.99	8.64	8.86	9.22	2.57	
					2	12.7	8.43	13.72	8.15	7.65			
M8 x 1.25	AUIUA	AUIUB	AUIUC	M8	1	8.51	11.91	11.15	9.53	10.95	11.38	3.07	
					2	14.27	10.31	15.29	10.19	8.51			

(1) Thread tapped thru, Class 3A/4h screw must pass with finger torque, but basic go gauge may stop at last thread.

## PERFORMANCE DATA FOR AUIUA, AUIUB, AUIUBB, AUIUC AND AUIUCC INSERTS

METRIC	Thread Code	ABS		Polycarbonate	
		Pullout (N)	Torque-out (N-m)	Pullout (N)	Torque-out (N-m)
M2-1	334	0.3	400	0.7	
M2.5-1	334	0.3	400	0.7	
M2.5-2	334	0.3	400	0.7	
M3-1	356	0.5	712	0.8	
M3-2	356	0.5	712	0.8	
M3.5-1	645	1.7	734	2	
M3.5-2	1223	1.7	2002	2.7	
M4-1	912	2	1312	2.3	
M4-2	1646	2.1	2869	2.3	
M5-1	1201	5.1	1913	6.2	
M5-2	2491	6.8	4048	9	
M6-1	1664	7.3	2731	9.6	
M6-2	3025	7.3	6294	12.2	

# MOLDED-IN INSERTS

## Blind Threaded, AUIBA™, AUIBB™ and AUIBC™ Inserts.

- Blind-end protects the threads from plastic intrusion.
- Aluminum inserts ideal for light weight designs.
- Aluminum and stainless steel inserts offer lead-free alternative.

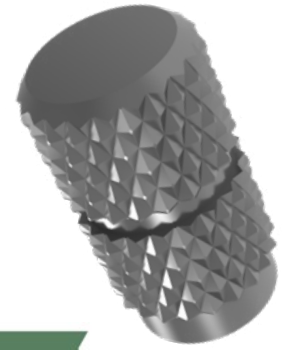

**NOTE:** Manufacturing techniques may leave a slight projection a maximum of .025" / 0.65 mm beyond the "A" dimension.

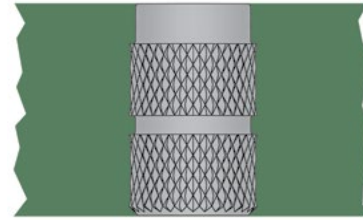
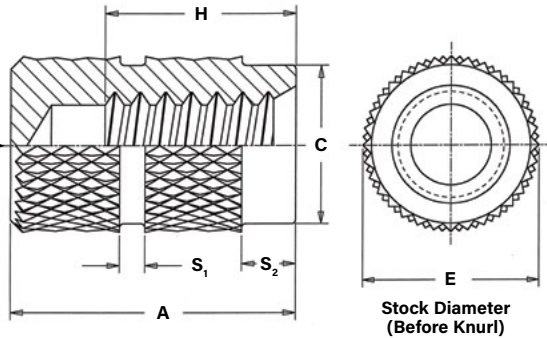

All dimensions are in millimeters.

METRIC	Thread Size x Pitch	Type			Thread Code	Length A ± 0.13 / H Min.					E Nom.	C ± 0.13	S <sub>1</sub> Nom.	S <sub>2</sub> Nom.	Minor Dia. Min./Max.
		Aluminum	Brass	Stainless Steel		Min. No. of Full Threads									
		4	6	8		10	12								
	M2.5 x 0.45	AUIBA	AUIBB	AUIBC	M2.5	4.78/2.01	6.35/2.87	7.14/3.74	9.53/4.6	10.31/5.47	4.78	4.34	0.8	0.8	2.03/2.14
	M3 x 0.5	AUIBA	AUIBB	AUIBC	M3	5.21/2.21	7.13/3.21	8.73/4.21	10.31/5.21	11.13/6.21	4.78	4.34	0.8	0.8	2.47/2.59
	M3.5 x 0.6	AUIBA	AUIBB	AUIBC	M3.5	6.35/2.62	8.73/3.81	10.31/5.02	11.91/6.22	13.48/7.42	5.56	5.13	0.8	1.6	2.87/3.01
	M4 x 0.7	AUIBA	AUIBB	AUIBC	M4	6.35/3.08	8.73/4.47	10.31/5.89	11.91/7.29	13.48/8.69	6.35	5.74	1.2	1.6	3.25/3.42
	M5 x 0.8	AUIBA	AUIBB	AUIBC	M5	7.13/3.49	11.12/5.09	13.48/6.69	11.91/8.29	13.48/9.89	7.14	6.57	1.2	1.6	4.15/4.34
	M6 x 1	AUIBA	AUIBB	AUIBC	M6	8.73/4.37	13.49/6.37	15.87/8.37	18.26/10.57	20.8/12.37	8.74	8.15	1.6	2.4	4.94/5.16
	M8 x 1.25	AUIBA	AUBB	AUIBC	M8	11.13/5.72	15.09/7.82	18.24/10.32	20.62/12.82	22.23/15.32	11.13	10.26	1.98	2.4	6.68/6.92

## PERFORMANCE DATA FOR AUIBA, AUIBB, AND AUIBC INSERTS

METRIC	Thread Code	Length Code	ABS		Polycarbonate	
			Pullout (N)	Torque-out (N-m)	Pullout (N)	Torque-out (N-m)
			M2.5/M3	4	1105 / 1050	0.69 / 0.63
6	1110 / 1060	0.7 / 0.64		1170 / 1120	0.77 / 0.73	
8	1115 / 1070	0.71 / 0.65		1180 / 1140	0.78 / 0.74	
10	1120 / 1080	0.72 / 0.66		1190 / 1160	0.79 / 0.74	
12	1125 / 1090	0.73 / 0.67		1200 / 1180	0.8 / 0.75	
M4	4	2340 / 2300	1.66 / 1.54	2415 / 2370	1.79 / 1.72	
	6	2350 / 2310	1.69 / 1.59	2420 / 2380	1.81 / 1.74	
	8	2360 / 2320	1.74 / 1.64	2425 / 2390	1.83 / 1.77	
	10	2370 / 2330	1.78 / 1.69	2430 / 2400	1.85 / 1.79	
	12	2380 / 2340	1.83 / 1.74	2435 / 2410	1.87 / 1.82	
M5	4	2815 / 2760	6.39 / 5.8	2870 / 2825	6.6 / 6.26	
	6	2820 / 2770	6.44 / 5.87	2880 / 2840	6.66 / 6.32	
	8	2825 / 2780	6.5 / 5.94	2885 / 2855	6.72 / 6.38	
	10	2830 / 2790	6.55 / 6.1	2890 / 2870	6.78 / 6.44	
	12	2835 / 2800	6.61 / 6.17	2895 / 2885	6.84 / 6.7	
M6	6	4040 / 3980	12.2 / 11.6	4120 / 4050	12.5 / 12	

# MOLDED-IN INSERTS

## Thru-Threaded, Knurled, AUSTKA™, AUSTKB™ and AUSTKC™ Inserts.

- Uniform knurl diameter reduces the risk of sink marks.
- Available in varying lengths for injection molding assemblies.
- Aluminum inserts ideal for light weight designs.
- Aluminum and stainless steel inserts offer lead-free alternative.

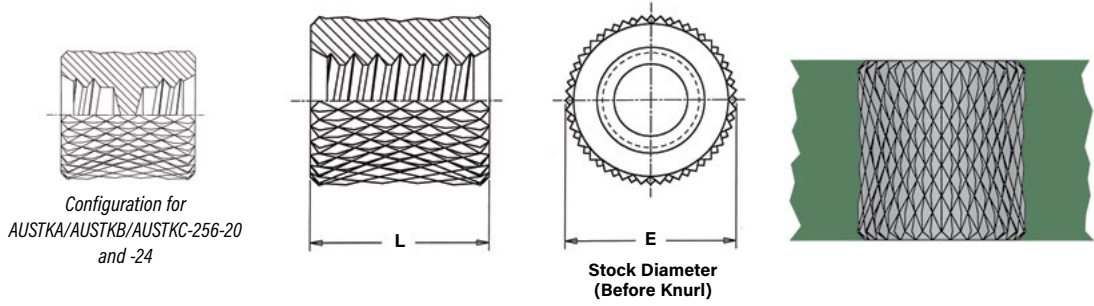
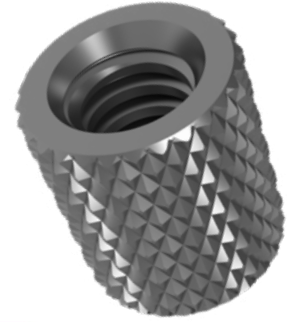

Configuration for  
AUSTKA/AUSTKB/AUSTKC-256-20  
and -24

All dimensions are in millimeters.

METRIC	Thread Size x Pitch	Type			Thread Code (1)	Length Code "L" ±0.13 in millimeters								E Nom.	Minor Dia. Min./Max.
		Aluminum	Brass	Stainless Steel											
	M3 x 0.5	AUSTKA	AUSTKB	AUSTKC	M3	3	4	6	8	10	12	15	18	4.74	2.47/2.59
	M4 x 0.7	AUSTKA	AUSTKB	AUSTKC	M4	3	4	6	8	10	12	15	18	6.35	3.25/3.42
	M5 x 0.8	AUSTKA	AUSTKB	AUSTKC	M5	3	4	6	8	10	12	15	18	7.13	4.15/4.34

(1) Thread tapped thru, Class 3A/4h screw must pass with finger torque, but basic go gauge may stop at last thread.

# MOLDED-IN INSERTS

## Hexagonal, AUNFPA™ and AUNFPC™ Inserts.

- Press-fit insert provides strong, reusable threads. No heat or ultrasonics required.
- Hexagonal “barbed” configuration ensures high torque-out and pullout values.
- Aluminum inserts ideal for light weight designs.
- Aluminum and stainless steel inserts offer lead-free alternative.

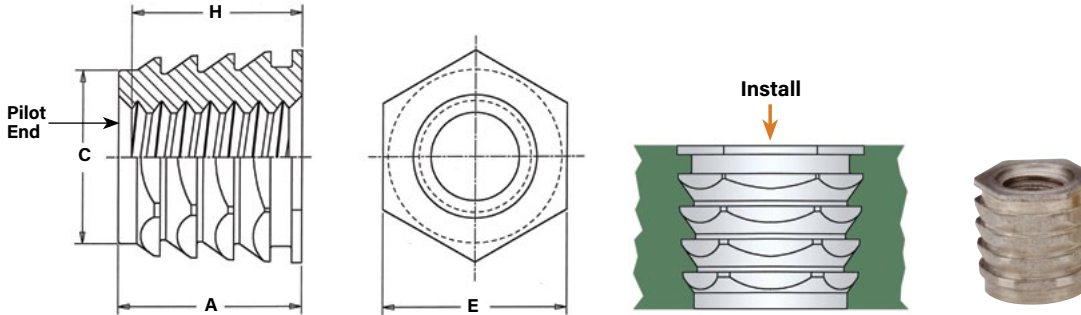
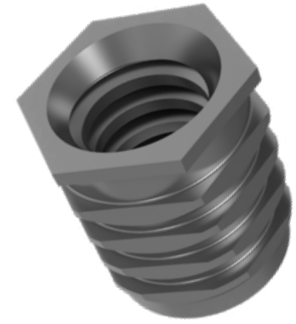

All dimensions are in millimeters.

METRIC	Thread Size x Pitch	Type		Thread Code	A Max.	Min. Material Thickness	Hole Size in Material + 0.08	C Max.	E Nom.	Min. Boss Dia.	Min. Depth Full Thread H <sup>(1)</sup>
		Aluminum	Stainless Steel								
	M2.5 x 0.45	AUNFPA	AUNFPC	M2.5	5.84	6.1	4.75	4.72	4.75	12.7	5.38
	M3 x 0.5	AUNFPA	AUNFPC	M3	5.84	6.1	4.75	4.72	4.75	12.7	5.38
	M3.5 x 0.6	AUNFPA	AUNFPC	M3.5	5.84	6.1	4.75	4.72	4.75	12.7	5.38
	M4 x 0.7	AUNFPA	AUNFPC	M4	6.73	6.99	6.35	6.32	6.35	15.88	6.3
	M5 x 0.8	AUNFPA	AUNFPC	M5	6.73	6.99	6.35	6.32	6.35	15.88	6.3
	M6 x 1	AUNFPA	UNFPC	M6	8	8.33	7.92	7.89	7.92	19.05	7.62
	M8 x 1.25	AUNFPA	AUNFPC	M8	9.27	9.65	9.53	9.50	9.53	24.13	8.76

(1) Thread tapped thru, Class 3A/4h screw must pass with finger torque, but basic go gauge may stop at pilot end.

## PERFORMANCE DATA FOR AUNFPA AND AUNFPC INSERTS

METRIC	Thread Code	ABS			Polycarbonate		
		Install. Force (kN)	Pullout (N)	Torque-out (N · m)	Install. Force (kN)	Pullout (N)	Torque-out (N · m)
	M3	1	556	0.45	2.67	1245	1.8
	M4	1.33	600	1.13	2.67	1690	4.74
	M5	1.33	600	1.13	2.67	1690	4.74
	M6	1.78	1045	3.16	-	-	-



#### **NORTH AMERICA**

**Danboro, Pennsylvania USA**  
[info@pemnet.com](mailto:info@pemnet.com)  
+1-215-766-8853  
800-237-4736 (USA)

**Querétaro, Mexico**  
[JMayagoitia@pemnet.com](mailto:JMayagoitia@pemnet.com)

#### **EUROPE**

**Galway, Ireland**  
[europe@pemnet.com](mailto:europe@pemnet.com)  
+353-91-751714

#### **ASIA/PACIFIC**

**Japan**  
[daiyou@pemnet.jp](mailto:daiyou@pemnet.jp)  
+042-798-7177

**Singapore**  
[singapore@pemnet.com](mailto:singapore@pemnet.com)  
+65-6645-9271

**Kunshan, China**  
[salesgreaterchina@pemnet.com](mailto:salesgreaterchina@pemnet.com)  
+0512-57269300

**Suwon, South Korea**  
[korea@pemnet.com](mailto:korea@pemnet.com)  
+82-10-2992-8597

### **CONNECT WITH PENNINGENGINEERING®**

Follow us for the latest company and product news, bulletin updates, tech tips, videos, and more.

