

PEM SERTER[®] SERIES 2000XT[™]

WITH 10 TONS OF RAM FORCE

The **PEMSERTER[®] Series 2000XT[™] automatic fastener-installation press system** provides 89 kN / 10 tons of ram force to install large thread size fasteners into stainless steel. The press features an 45.7 cm / 18" throat depth which provides clearance for a variety of chassis configurations.

Features and Benefits

- ▶ The job search and recall mode allows operators to reference 300 stored jobs and return to previous jobs quickly and easily.
- ▶ PLC readily accommodates custom programs.
- ▶ A cast aluminum bowl with epoxy coating handles larger parts and performs quietly.
- ▶ A wide feeder track increases fastener-feeding rates; the robust shuttle support design improves small-fastener feeding.
- ▶ A larger touch-screen and graphics contribute to operator-friendly operation.
- ▶ The press is Ethernet capable and expandable to interface with data collection systems, production management systems, and off-site troubleshooting systems.
- ▶ Adjustable ram stroke distance control in manual and bottom feed nut mode.
- ▶ Real-time installation force feedback displayed on screen.
- ▶ Fastener and batch counters.
- ▶ Descriptive screen alerts for operating errors.
- ▶ Smart dwell and force verification.
- ▶ Self-diagnostic system lets operator work with increased speed, accuracy, and confidence.
- ▶ LightStream[®] Operator Safety System provides continuous operator and workpiece protection.
- ▶ Color-coded tooling for quick changeover.



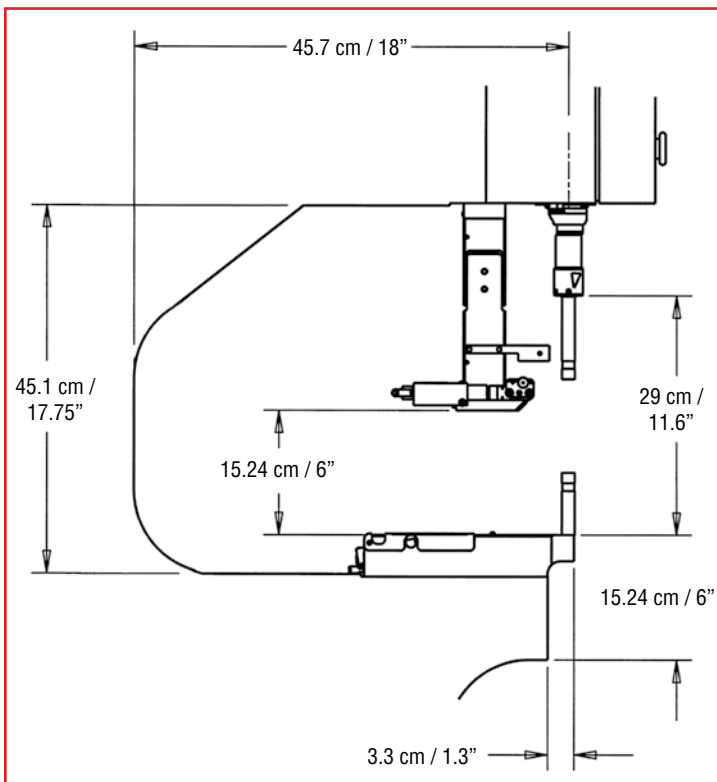

Specifications

Ram Force 1.8 to 89 kN / 400 to 20,000 lbs.

Pressure System Type Air-Over-Oil

Electric Requirements 120V 60Hz 4A or
230V 50Hz 2A single phase

Air Requirements* 6 to 7 BAR / 90 to 100 PSI
12 mm / 1/2" dia. minimum line flow

Throat Depth 45.7 cm / 18"

Height 193 cm / 76"

Width 92 cm / 36"

Depth 126 cm / 49.5"

Weight 1,135 kg / 2,500 lbs.

*1 psi = 0.07 bar. 1 bar = 14.5 psi.

The Series 2000XT press utilizes a programmable logic controller and a menu-driven touch screen operator interface system, in eleven available languages. Touch screens allow for quick-run-set-up, easy operator training, and precise fastener installation setups. They also allow the operator to instantly adjust installation variables such as dwell time and installation force and automatically alert and direct the operator to any safety or system faults for quick diagnosis.



The Series 2000XT press has a unique patented LightStream® Operator Safety System. It is a wireless, fail-safe system which utilizes a pair of infrared beams that immediately detect when the main ram contacts any object, metallic or non-metallic, that should not be in its path. The LightStream system provides a fast, precise, and reliable safety system that ensures ram force is only applied to fasteners during installation.



Specifications subject to change without notice.
Check our website for the most current version of this bulletin.

© 2008, PennEngineering

PennEngineering®



North America: Danboro, PA USA • E-mail: info@pemnet.com • Tel: +1-215-766-8853 • Fax: +1-215-766-0143 • 800-237-4736 (USA Only)

Europe: Galway, Ireland • E-mail: europe@pemnet.com • Tel: +353-91-751714 • Fax: +353-91-753541

Asia/Pacific: Singapore • E-mail: singapore@pemnet.com • Tel: +65-6-745-0660 • Fax: +65-6-745-2400
Shanghai, China • E-mail: china@pemnet.com • Tel: +86-21-5868-3688 • Fax: +86-21-5868-3988

Visit our PEMNET™ Resource Center at www.pemnet.com