

PennEngineering®

SELF-CLINCHING NUTS



BULLETIN **CL**



SELF-CLINCHING NUTS

Self-clinching nuts are installed by placing them in properly sized holes in sheets and applying a parallel squeezing force to the head of the nut. The sheet metal surrounding the head cold flows into an undercut thereby making the fastener an integral part of the sheet. A serrated clinching ring prevents the fastener from rotating after installation.

Type S, SS, CLS, and CLSS nuts (pages CL-4 and CL-5) provide load-bearing threads in thin sheets with high pushout and torque-out resistance.

Type SP, PEM 300® nuts (pages CL-4 and CL-5) provide strong load-bearing threads in stainless steel sheets as thin as .030"/0.8mm.

Type CLA aluminum nuts (pages CL-4 and CL-5) are recommended for use in aluminum sheet with a hardness of HRB 50 or less on the Rockwell "B" scale.

Type H and HN (non-locking) and Type HNL (locking) nuts (page CL-6) self-clinching nuts.

Type SMPS self-clinching nuts (page CL-6) are for installation into ultra-thin sheets. They feature a lower profile and can be mounted closer to the edge of a sheet than other self-clinching nuts.

Type SL self-locking nuts (page CL-7) are designed with a unique and economical TRI-DENT® locking feature, which meets demanding locking performance requirements.

Many PEM self-clinching nuts meet NASM45938/1 specifications. Consult our Marketing department for a complete Military Specifications and National Aerospace Standards guide (Bulletin NASM) or check our website.

PART NUMBER DESIGNATION

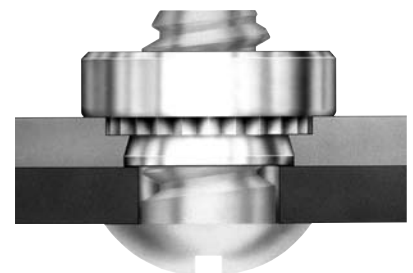
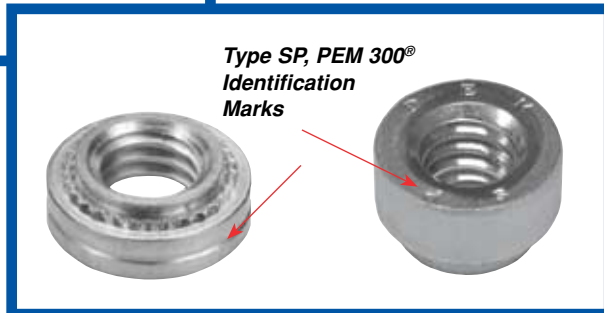
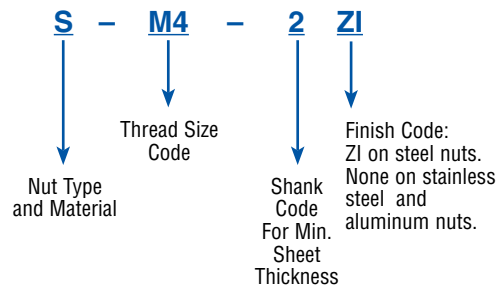

SELF-CLINCHING NUTS

PEM® SELF-CLINCHING NUT SELECTOR GUIDE

PEM Nut Type	Page No.	Recommended Application						
		Sheet thickness as thin as .025" / 0.64mm	Self-locking	Reduced centerline-to-edge distance	Max. corrosion resistance	Recommended for use in steel or aluminum panels within specified hardness limits	Recommended for use in aluminum panels within specified hardness limits	Recommended for use in stainless steel panels within specified hardness limits
S/SS	4, 5					•		
CLS/CLSS	4, 5				•	•		
CLA	4, 5				•		•	
SP	4, 5				•			•
H	6					•		
HN	6					•		
HNL	6		•			•		
SMPS	6	•		•	•	•		
SL	7		•			•		

SELF-CLINCHING FASTENER INSTALLATION DO'S AND DON'TS

“DO’S”

- DO** select the proper fastener material to meet corrosion requirements.
- DO** make certain that panel material is in the annealed condition.⁽¹⁾
- DO** make certain that hole punch is kept sharp to minimize work hardening around hole.
- DO** maintain the punch diameter to no greater than +.025mm over the minimum recommended mounting hole for type SP nuts into stainless steel sheets.
- DO** provide mounting hole of specified size for each fastener.
- DO** install fastener into punch side of sheet.
- DO** make certain that shank (or pilot) is within hole before applying installation force.
- DO** make certain that fastener is not installed adjacent to bends or other highly cold-worked areas.
- DO** apply squeezing force between parallel surfaces.
- DO** utilize recommended installation tooling when installing fasteners.
- DO** apply sufficient force to totally embed clinching ring around entire circumference and to bring shoulder squarely in contact with sheet. For some fasteners, installation will be complete when the head is flush with the panel surface.

“DON'TS”

- DON'T** attempt to install any self-clinching nut other than a type SP fastener into a stainless steel sheet.
- DON'T** install steel or stainless steel fasteners in aluminum panels before anodizing or finishing.
- DON'T** deburr mounting holes on either side of sheet before installing fasteners – deburring will remove metal required for clinching fastener into sheet.
- DON'T** install fastener closer to edge of sheet than minimum edge distance indicated by manufacturer – unless a special fixture is used to restrict bulging of sheet edge.
- DON'T** over-squeeze. It will crush the head, distort threads, and buckle the sheet. Approximate installation forces are listed in performance data tables. Use this info as a guide. Be certain to determine optimum installation force by test prior to production runs.
- DON'T** attempt to insert fastener with a hammer blow – under any circumstances. A hammer blow won't permit the sheet metal to flow and develop an interlock with the fastener's contour.
- DON'T** install screw in the head side of fastener. Install from opposite side so that the fastener load is toward sheet. The clinching force is designed only to hold the fastener during handling and to resist torque during assembly.
- DON'T** install fastener on pre-painted side of panel.

SELF-CLINCHING NUTS

- Types S and SS are recommended for use in steel or aluminum sheets HRB (Rockwell “B” scale) 80 or less and HB (Hardness Brinell) 150 or less.
- Types CLS and CLSS are recommended for use in steel or aluminum sheets HRB (Rockwell “B” scale) 70 or less and HB (Hardness Brinell) 125 or less.
- Type SP is recommended for use in steel or aluminum sheets HRB (Rockwell “B” scale) 90 or less and HB (Hardness Brinell) 185 or less.

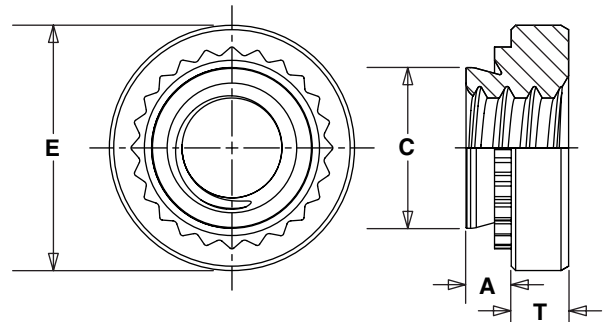

(Clinching profile may vary)
Due to manufacturing procedure,
parts may have a counterbore at shank end.

TYPES S, SS, CLS, CLSS, AND SP

(See drawing at top of page CL-4) All dimensions are in millimeters.

METRIC	Thread Size	Type			Thread Code	Shank Code	A (Shank) Max.	Rec. Min. Sheet Thickness (1)	Hole Size In Sheet +0.08	C Max.	E ±0.25	T ±0.25	Min. Dist. Hole ϕ To Edge (2)
		Fastener Material											
		Carbon Steel	Stainless Steel	Hardened Stainless Steel									
M2 x 0.4	S	CLS	NA	M2	0	0.77	0.8	4.22	4.2	6.3	1.5	4.8	
					1	0.97	1						
					2	1.38	1.4						
M2.5 x 0.45	S	CLS	NA	M2.5	0	0.77	0.8	4.22	4.2	6.3	1.5	4.8	
					1	0.97	1						
					2	1.38	1.4						
M3 x 0.5	S	CLS	SP	M3	0	0.77	0.8	4.22	4.2	6.3	1.5	4.8	
					1	0.97	1						
					2	1.38	1.4						
M3.5 x 0.6	S	CLS	NA	M3.5	0	0.77	0.8	4.75	4.73	7.1	1.5	5.6	
					1	0.97	1						
					2	1.38	1.4						
M4 x 0.7	S	CLS	SP	M4	0	0.77	0.8	5.41	5.38	7.9	2	6.9	
					1	0.97	1						
					2	1.38	1.4						
M5 x 0.8	SS	CLSS	SP	M5	0	0.77	0.8	6.35	6.33	8.7	2	7.1	
					1	0.97	1						
					2	1.38	1.4						
M6 x 1	S	CLS	SP	M6	00 ⁽³⁾	0.89	0.92	8.75	8.73	11.05	4.08	8.6	
					0 ⁽³⁾	1.15	1.2						
					1	1.38	1.4						
					2 ⁽³⁾	2.21	2.3						
M8 x 1.25	S	CLS	SP	M8	1	1.38	1.4	10.5	10.47	12.65	5.47	9.7	
					2 ⁽³⁾	2.21	2.3						
M10 x 1.5	S	CLS	SP	M10	1	2.21	2.31	14	13.97	17.35	7.48	13.5	
					2 ⁽³⁾	3.05	3.18						
M12 x 1.75	S	NA	NA	M12	1	3.05	3.18	17	16.95	20.55	8.5	16	

(1) For maximum performance, we recommend that you use the maximum shank length for your sheet thickness.

(2) To minimize sheet distortion and maximize product performance, use a centerline-to-edge value greater or equal to the value specified.

(3) This length code not available for Type SP.

NA - Not Available.

The increased hardness of stainless steel panels requires careful consideration when installing self-clinching fasteners. Refer to Do's and Don'ts on page CL-3 for further information.

SELF-CLINCHING NUTS

TYPE CLA

- Type CLA is recommended for use in steel or aluminum sheets HRB (Rockwell "B" scale) 50 or less and HB (Hardness Brinell) 82 or less.

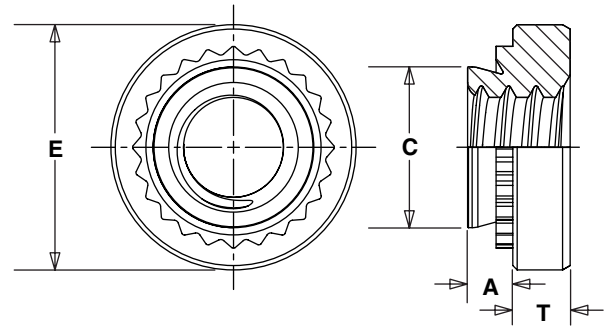

(Clinching profile may vary)
Due to manufacturing procedure,
parts may have a counterbore at shank end.

METRIC	Thread Size x Pitch	Type	Thread Code	Shank Code	A (Shank) Max.	Min. Sheet Thickness (1)	Hole Size In Sheet +0.08	C Max.	E ±0.25	T ±0.25	Min. Dist. Hole \varnothing To Edge (2)
		Fastener Material									
		Aluminum									
M2 x 0.4	CLA	M2	1	0.98	1	4.25	4.22	6.3	1.5	4.8	
			2	1.38	1.4						
M3 x 0.5	CLA	M3	1	0.98	1	4.75	4.73	6.3	2	5.6	
			2	1.38	1.4						
M3.5 x 0.6	CLA	M3.5	1	0.98	1	5.4	5.38	7.1	2	6.9	
			2	1.38	1.4						
M4 x 0.7	CLA	M4	1	0.98	1	6	5.97	7.9	3	7.1	
			2	1.38	1.4						
M5 x 0.8	CLA	M5	1	0.98	1	7.5	7.47	9.5	3.8	7.9	
			2	1.38	1.4						
M6 x 1	CLA	M6	1	1.38	1.4	8.75	8.72	11.05	4.08	8.6	
			2	2.21	2.3						

(1) For maximum performance, we recommend that you use the maximum shank length for your sheet thickness.

(2) To minimize sheet distortion and maximize product performance, use a centerline-to-edge value greater or equal to the value specified.

SELF-CLINCHING NUTS

STEEL, SELF-LOCKING AND NON-LOCKING NUTS - TYPES H, HN AND HNL

- Meets torque requirements for IFI 100/107 Grade B (unified) and ANSI B18.16.1M (metric) locknuts.
- Type H is recommended for use in sheets HRB (Rockwell "B" scale) 80 or less and HB (Hardness Brinell) 150 or less.
- Type HN and HNL are recommended for use in sheets HRB (Rockwell "B" scale) 60 or less and HB (Hardness Brinell) 107 or less.

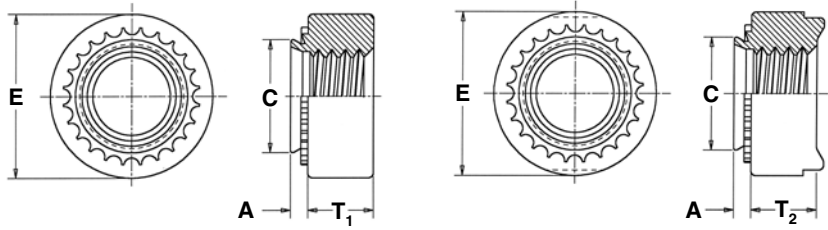

All dimensions are in millimeters.

METRIC	Thread Size x Pitch	Type		Thread Code	A (Shank) Max.	Min. Sheet Thickness	Hole Size In Sheet +0.13	C Max.	E ±0.25	T ₁	T ₂	Min. Dist. Hole ϕ To Edge (2)
		Non-Locking	Self-Locking (1)							Non-locking	Self-locking	
										±0.13	±0.25	
	M6 x 1	NA	HNL	M6	1.48	1.48	8.75	8.72	12.7	5	5	10
	M8 x 1.25	NA	HNL	M8	1.48	1.48	10.5	10.47	14.6	6.3	6.3	11
	M10 x 1.5	H HN	HNL	M10	1.48	1.48	12.7	12.67	16.5	7.9	7.9	12

- (1) During installation, the projections on the heads of Type HNL self-locking nuts may be flattened. This is not detrimental in any way and will not affect self-locking or self-clinching performance.
 - (2) To minimize sheet distortion and maximize product performance, use a centerline-to-edge value greater or equal to the value specified.
- NA Not Available - Use Type S instead.

NUTS FOR ULTRA-THIN SHEETS - TYPE SMPS™

- Installs into sheets as thin as .025" / 0.64mm.
- Recommended for use in sheets HRB (Rockwell "B" scale) 70 or less and HB (Hardness Brinell) 125 or less.

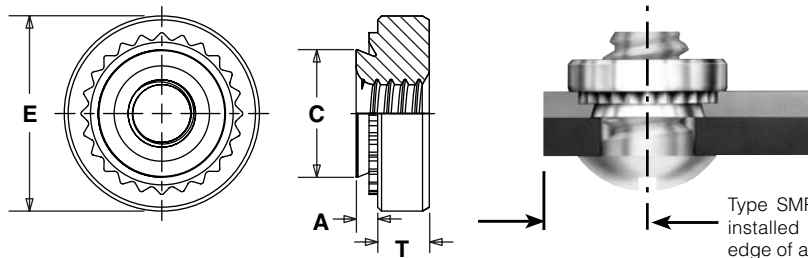

Type SMPS nuts can be installed closer to the edge of a sheet than nuts on pages CL-4 and CL-5.

All dimensions are in millimeters.

METRIC	Thread Size x Pitch	Type	Thread Code	A (Shank) Max.	Min. Sheet Thickness	Hole Size In Sheet +0.08	C Max.	E ±0.25	T ±0.25	Min. Dist. Hole ϕ To Edge
	M2.5 x 0.45	SMPS	M2.5	0.61	0.64	3.8	3.79	5.6	1.4	3.7
	M3 x 0.5	SMPS	M3	0.61	0.64	4.24	4.22	5.6	1.4	4.3
	M3.5 x 0.6	SMPS	M3.5	0.61	0.64	4.75	4.73	6.4	1.4	5.1

SELF-CLINCHING NUTS

TRIDENT® LOCKNUTS - TYPE SL™

- 3 cycle locking performance. ⁽¹⁾
- Recommended for use in sheets HRB (Rockwell “B” scale) 80 or less and HB (Hardness Brinell) 150 or less.

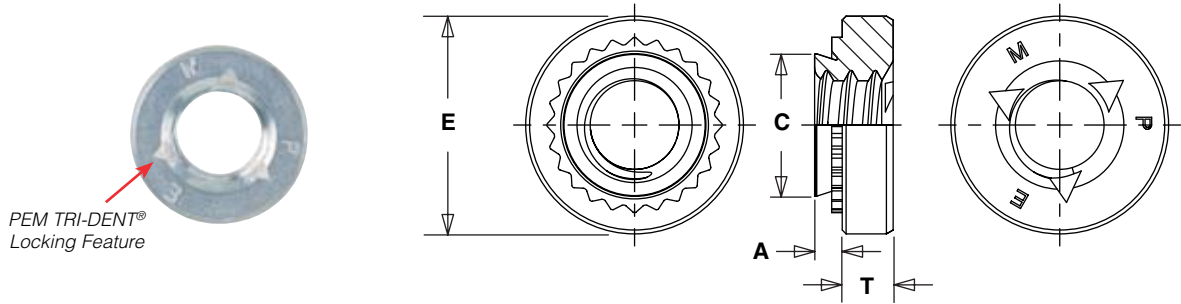

All dimensions are in millimeters.

METRIC	Thread Size x Pitch	Type	Thread Code	Shank Code	A (Shank) Max.	Min. Sheet Thickness	Hole Size In Sheet +0.08	C Max.	E ±0.25	T ±0.25	Min. Dist. Hole To Edge
	M3 x 0.5	SL	M3	1	0.98	1	4.25	4.22	6.3	1.5	4.8
2				1.38	1.4						
M3.5 x 0.6	SL	M3.5	1	0.98	1	4.75	4.73	7.1	1.5	5.6	
			2	1.38	1.4						
M4 x 0.7	SL	M4	1	0.98	1	5.4	5.38	7.9	2	6.9	
			2	1.38	1.4						
M5 x 0.8	SL	M5	1	0.98	1	6.4	6.38	8.7	2	7.1	
			2	1.38	1.4						
M6 x 1	SL	M6	1	1.38	1.4	8.75	8.73	11.05	4.08	8.6	
			2	2.21	2.3						
M8 x 1.25	SL	M8	1	1.38	1.4	10.5	10.47	12.65	5.47	9.7	
			2	2.21	2.3						

(1) Achieved using steel socket head cap screws, 180 ksi / property class 12.9 with standard finish of thermal oxide and light oil.

SELF-CLINCHING NUTS

INSTALLATION - Type SP⁽¹⁾ - Identified With Stamp

1. Prepare properly sized mounting hole in sheet. Do not perform any secondary operations such as deburring.
2. Place fastener into the recommended counterbored anvil hole and place the mounting hole over the shank of the fastener as shown in diagram.
3. With punch and anvil surfaces parallel, apply squeezing force until the head of the nut comes into contact with the sheet material.

METRIC	Thread Code	Anvil Dimensions (mm)				Anvil Part No.
		A ±0.05	P -0.03	R Max.	R ₁ +0.13	
	M3	6.48	1.63	0.25	0.13	8012821
	M3.5	7.26	1.63	0.25	0.13	8012822
	M4	8.05	2.08	0.25	0.13	8012823
	M5	8.84	2.08	0.25	0.13	8012824
	M6	11.25	4.14	0.25	0.13	8012825
	M8	12.83	5.41	0.25	0.13	8015360
	M10	17.58	7.46	0.25	0.13	8015886

RECOMMENDED COUNTERBORED INSTALLATION ANVIL

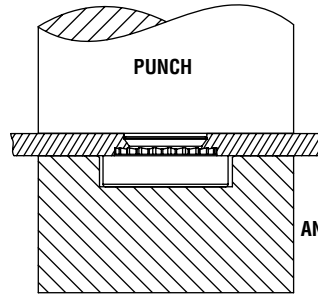
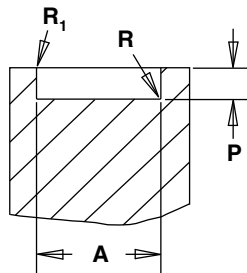

Identified With Stamp



(1) To meet the published performance data, we recommend using the installation punch and anvil shown. Deviations from recommended installation tooling may result in sheet distortion and reduced performance.

NOTE: Variations in hole preparation, installation tooling, installation force, and sheet material type, thickness, and hardness will affect both performance and tooling life.

INSTALLATION - Type SP⁽¹⁾ - Identified With Single Ring

A special punch with a pilot pin to align the nut and a special anvil with a pilot pin to align the sheet and a raised ring is required to create a proper installation. The raised ring acts as a second displacer of the stainless sheet material, thereby ensuring proper installation.

1. Prepare properly sized mounting hole in sheet. Do not perform any secondary operations such as deburring.
2. Place sheet on raised ring anvil.
3. Place fastener in hole.
4. With punch and anvil surfaces parallel, apply squeezing force until the head of the nut comes into contact with the sheet material.



Identified with single ring

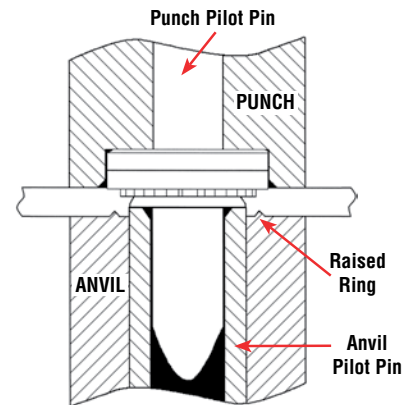

RECOMMENDED COUNTERBORED INSTALLATION PUNCH

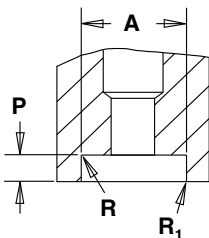

RECOMMENDED RAISED RING INSTALLATION ANVIL

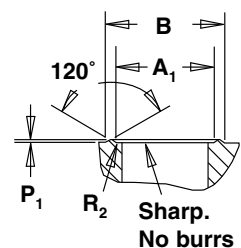

METRIC	Thread Code	Punch Dimensions (mm)				Punch Part No.
		A ±0.05	P ±0.03	R Max.	R ₁ +0.13	
	M3	6.48	1.42	0.25	0.13	8002695
	M3.5	7.26	1.42	0.25	0.13	8002696
	M4	8.05	1.93	0.25	0.13	8002697
	M5	8.84	1.93	0.25	0.13	8002698
	M6	—	—	—	—	(3)

METRIC	Thread Code	Anvil Dimensions (mm)				Anvil Part No.
		A ₁ ±0.05	B Nom.	P ₁ (2) +0.03	R ₂ Max.	
	M3	5.05	6.63	.23	.08	8002687
	M3.5	5.54	7.11	.23	.08	8002688
	M4	6.17	7.75	.23	.08	8002689
	M5	7.34	7.75	.23	.08	8002690
	M6	—	—	—	—	(3)

(1) To meet the published performance data, we recommend using the installation punch and anvil shown. Deviations from recommended installation tooling may result in sheet distortion and reduced performance.

(2) We recommend replacing installation anvil when the height of the "P1" dimension is reduced to 0.13mm due to wear. Reductions in performance may occur as the height of the protrusion wears.

(3) Special installation tooling for M6 thread size is not required.

NOTE: Variations in hole preparation, installation tooling, installation force, and sheet material type, thickness, and hardness will affect both performance and tooling life.

SELF-CLINCHING NUTS

INSTALLATION - TYPE S, SL, SMPS, SS, CLS, CLSS, CLA, H, HN, AND HNL

1. Prepare properly sized mounting hole in sheet. Do not perform any secondary operations such as deburring.
2. Place fastener into the anvil hole and place the mounting hole over the shank of the fastener as shown in diagram to the right.
3. With punch and anvil surfaces parallel, apply squeezing force until the head of the nut comes into contact with the sheet material.

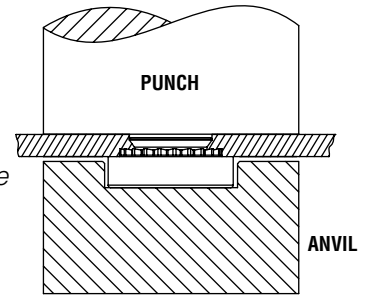

NOTE: For manual and automatic tooling part numbers, see tooling guides on our web site at www.pemnet.com/presses/tooling_guides.html

PEMSERTER® PRESSES

For best results we recommend using a PEMSERTER® press for either manual or automatic installation of PEM type S, SL, SMPS, SS, CLS, CLSS, CLA, H, HN, HNL, and SP nuts. For more information on our line of presses call 1-800-523-5321, or check our web site.

PERFORMANCE DATA⁽¹⁾

TYPE SP

METRIC	Type	Thread Code	Shank Code	Test Sheet Material	Installation (kN)	Pushout (N)	Torque-out (N•m)
	METRIC	SP	M3	0	304 Stainless Steel	35.6	575
1				40		725	1.92
2				44.5		1290	2.03
SP		M4	0	304 Stainless Steel	40	645	3.38
			1		44.5	800	4.18
			2		49	1600	5.08
SP		M5	0	304 Stainless Steel	42.3	800	3.95
			1		46.7	1025	5.08
			2		51.2	1775	6.77
SP	M6	1	304 Stainless Steel	60	2000	17	
SP	M8	1	304 Stainless Steel	66	2100	19	
SP	M10	1	304 Stainless Steel	80	2150	38	

TYPE SMPS

METRIC	Type	Thread Code	Test Sheet Material		
			Cold-rolled Steel		
			Installation (kN)	Pushout (N)	Torque-out (N•m)
SMPS	M2.5	7.5	156	1.13	
SMPS	M3	8	267	1.35	
SMPS	M3.5	8.8	289	1.58	

(1) The values reported are averages when all installation specifications and procedures are followed. Variations in mounting hole size, sheet material, and installation procedure will affect this data. Performance testing of this product in your application is recommended. We will be happy to provide samples for this purpose.

SELF-CLINCHING NUTS

PERFORMANCE DATA

TYPE S, CLS, CLSS

METRIC	Type	Thread Code	Shank Code	Test Sheet Material	Installation (kN)	Pushout (N)	Torque-out (N•m)			
	S CLS	S CLS	M2 M2.5 M3	0	5052-H34 Aluminum	6.7-8.9	280	0.9		
1				400			1.13			
2				750			1.47			
S CLS			M3.5	0	5052-H34 Aluminum	11.2-13.5	470	1.47		
							1	550	1.7	
							2	1010	2.03	
		S CLS		M4	0	5052-H34 Aluminum	11.2-13.4	300	2.37	
								1	470	2.6
								2	970	4
SS CLSS			M5		0	5052-H34 Aluminum	11.2-15.6	490	2.95	
								1	645	4
								2	1250	5.1
		S CLS		M6	00	5052-H34 Aluminum	18-32	750	6.5	
								0	970	7.9
								1	1580	10.2
S CLS			M8		1	5052-H34 Aluminum	18-32	13.6	18.1	
								2	18.7	20.3
								1	1870	20.3
	S CLS			M10	2	5052-H34 Aluminum	22-36	1760	32.7	
								1	2020	36.2
								2	2020	36.2
S			M12		1	5052-H34 Aluminum	23-30	1390	35.2	
					1	Cold-rolled Steel	33-49	3065	73.9	

TYPE H

METRIC	Type	Thread Code	Test Sheet Thickness and Sheet Material	Installation (kN)	Pushout (N)	Torque-out (N•m)
H	H	M10	2.29 mm 5052-H34 Aluminum	22	1760	21.5
			2.24 mm Cold-rolled Steel	33	2020	27.1

SELF-CLINCHING NUTS

PERFORMANCE DATA

TYPE SL

METRIC	Type	Thread Code	Shank Code	Thread Locking Specifications (1)		Test Sheet Material					
				Max. Torque (1st thru 3rd) (N•m)	Min. Torque (1st thru 3rd) (N•m)	5052-H34 Aluminum			Cold-rolled Steel		
						Installation (kN)	Pushout (N)	Torque-out (N•m)	Installation (kN)	Pushout (N)	Torque-out (N•m)
						1	2			1	2
SL	M3		1	0.67	0.04	6.7 - 8.9	400	1.13	11.2 - 15.6	550	1.7
			2				750	1.47		1010	2.03
SL	M3.5		1	1.2	0.08	11.2 - 13.5	400	1.92	13.4 - 26.7	570	2.3
			2				840	2.5		1210	2.3
SL	M4		1	2.1	0.13	11.2 - 13.4	470	2.6	18 - 27	645	4
			2				970	4		1250	5.1
SL	M5		1	2.4	0.18	11.2 - 15.6	480	3.6	18 - 38	800	4.5
			2				845	5.7		1112	6.8
SL	M6		1	4	0.30	18 - 32	1580	10.2	27 - 36	1760	17
			2				1580	14.1		1760	17
SL	M8		1	6	0.50	18 - 32	1570	13.6	27 - 36	1870	18.7
			2				1570	18.1		1870	20.3

(1) 3 cycle locking performance. PEM spec PRS-C90 Max. on / Min. off torque for 1st thru 3rd cycles.

PUSHOUT TEST

Pushout tests shall be performed from the grip or shank side of the installed fastener. An axial load shall be applied to the fastener as shown using a hardened test screw, while evenly supporting the test strip around the fastener. The typical position rate is 6.35mm per minute. Dimensions are identified per PEM Bulletins where "E" equals head diameter and "T" (or "L") equals head height. The pushout force is measured using a force or compression tester with a range that will cover the expected forces.

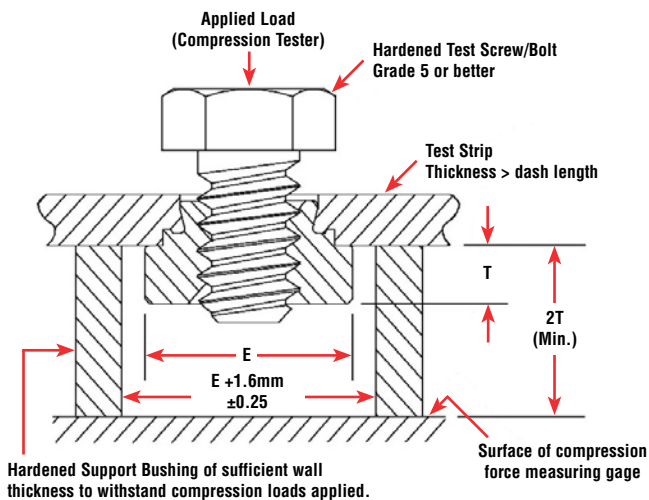

TORQUE-OUT TEST

Torque-out tests shall be performed from the shoulder or head side of the installed fastener. Torque shall be applied to the fastener in the manner illustrated, using a hardened test screw and washer, while firmly holding the test strip. Test screws should be of sufficient tensile strength to resist thread stripping. A minimum of two screw threads must extend beyond the fastener.

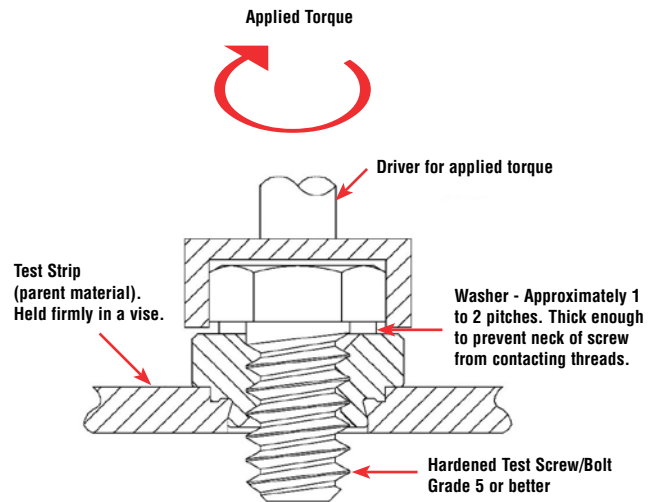

SELF-CLINCHING NUTS

MATERIAL AND FINISH SPECIFICATIONS

Type	Threads			Fastener Materials					Standard Finishes				Optional Finishes (1)		For Use in Sheet Hardness: (6)					
	Internal ASME B1.1 2B/ ASME B1.13M, 6H	Meets Torque Requirements for IFI 100/ 107 Grade B (unified) and ANSI B18. 16.1M (metric) Locknuts	3 Cycle Locking Performance PEM spec PRS-C90	Heat Treated Carbon Steel	300 Series Stainless Steel	Aluminum	Carbon Steel	Precipitation Hardening Grade Stainless Steel	Age Hardened A286 Stainless Steel	Passivated and/or Tested per ASTM A380	Zinc Plated, 5µm, Colorless (7)	Zinc Plated, 5µm, Colorless Plus Sealant/ Lubricant (7)	No Finish (2) (3)	Zinc Plated, 5µm, Yellow (7)	Cadmium Spec SAE AMS-QQ-P-416, Type I, Class 3, Plus Clear Chromate Passivation	HRB 90/ HB 185 or Less (4) (5)	HRB 80/ HB 150 or Less	HRB 70/ HB 125 or Less	HRB 60/ HB 107 or Less	HRB 50/ HB 82 or Less
S	•			•						•			•			•				
SS	•			•						•			•			•				
CLS	•				•				•									•		
CLSS	•				•				•									•		
CLA	•					•						•								•
SL	•		•	•						•							•			
SMPS	•				•				•									•		
SP Stamped	•							•	•							•				
SP Grooved	•						•		•							•				
H	•			•						•		•				•				
HN	•						•			•		•							•	
HNL	•	•					•				•			•					•	
Part number codes for finishes									None	ZI	LZ	X	ZC	CI						

- (1) Special order with additional charge.
- (2) Part numbers for aluminum nuts have no plating suffix.
- (3) Unplated threads are sized to accept a basic go gauge after .00025" plating.
- (4) Panel material should be in the annealed condition.
- (5) Fasteners should not be installed adjacent to bends or other highly cold-worked areas.
- (6) HRB - Hardness Rockwell "B" Scale. HB - Hardness Brinell.
- (7) See PEM Technical Support section of our web site for related plating standards and specifications.

Thread Mask

PEM® Blu-Coat™ thread mask is available for applications where hardware is installed prior to painting. During assembly, the threads of the mating hardware will remove paint, electro deposited automotive under coatings, and weld spatter upon application of torque. PEM nuts can be specially ordered with thread mask applied.



"BC" suffix will be added to part number to designate Blu-Coat thread mask to fastener.

RoHS compliance information can be found on our website.
© 2010 PennEngineering.

Specifications subject to change without notice.
Check our website for the most current version of this bulletin.

PennEngineering®



North America: Danboro, PA USA • E-mail: info@pemnet.com • Tel: +1-215-766-8853 • Fax: +1-215-766-0143 • 800-237-4736 (USA Only)
Europe: Galway, Ireland • E-mail: europe@pemnet.com • Tel: +353-91-751714 • Fax: +353-91-753541
Asia/Pacific: Singapore • E-mail: singapore@pemnet.com • Tel: +65-6-745-0660 • Fax: +65-6-745-2400
 Shanghai, China • E-mail: china@pemnet.com • Tel: +86-21-5868-3688 • Fax: +86-21-5868-3988

Visit our PEMNET™ Resource Center at www.pemnet.com